

Off-road Rubber Track Dumper

S500V

Operator's Manual

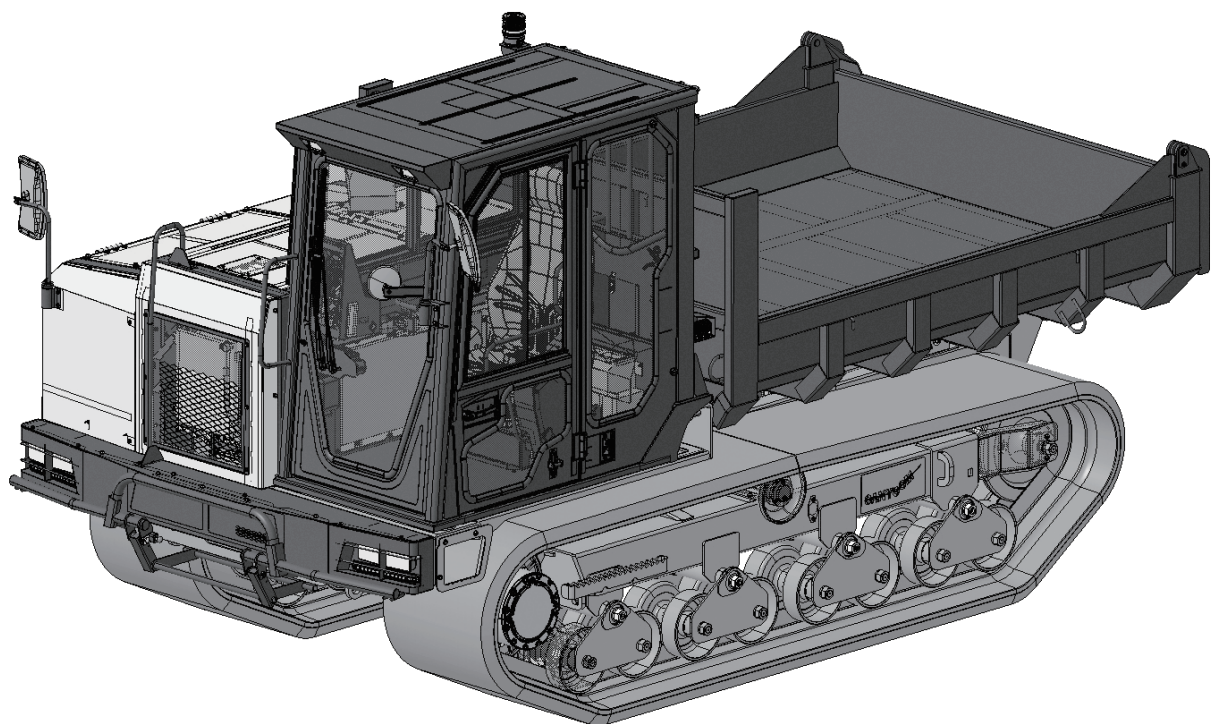

36AB 5601 002 00

Original Instructions (in English)

About This Manual

Thank you for using CANYCOM product.





This manual provides information needed for safe and effective use and maintenance of this machine to those who operate or service this machine. Read and understand this manual thoroughly before operating or servicing this machine. Also read the separate **operator's manual for the engine, Audio Manual, and Around View Camera Manual.**

NOTICE

- Always keep this manual with the machine for easy reference.
- Owner of this machine is responsible that anyone who uses or services this machine reads and understands this manual before use or service.

Warning Terms Used in this Manual

In this manual, the following four warning terms are used to signal the four levels of hazard (or seriousness of possible accidents). Read and understand what they mean and always follow the instructions in this manual to avoid these hazards.

Warning Term	Definition
	Indicates an imminently hazardous situation which will result in death or serious injury if not avoided.
	Indicates a potentially hazardous situation which could result in death or serious injury if not avoided.
	Indicates a potentially hazardous situation which could result in minor to moderate injury if not avoided.
	Indicates a potentially hazardous situation which could result in property damage if not avoided.

In addition, the following term is used to indicate important information.

	Indicates important information which needs particular attention.
---	---

Notice to Users and Maintenance Personnel

DANGER

- This machine can kill you if the safety precautions in this manual and on the labels attached to this machine are not followed. Read and understand this manual and the safety labels on the machine thoroughly before using or servicing this machine. Always follow the instructions and safety precautions, or serious injury or death could result.
- Do not modify this machine. Do not operate this machine with its safety covers removed or open, or with its safety devices and features disabled. Serious injury or death could result.

WARNING

- This product should only be used for its intended purpose: hauling and dumping. Any other use could be dangerous.
- This product may not be operated on public road or what is considered to be public road. It is the sole responsibility of the operator to consult the local regulations.

Notice to Owner or Renter

NOTICE

- Be sure that everyone who uses this product, including those who rent or lease this product, receives a copy of this Operator's Manual and understands the importance of reading and following the information in this manual.
-

Warranty and After-Sales Service

Warranty

CHIKUSUI CANYCOM, INC. guarantees this product, based on the terms of warranty.

After-Sales Service

Consult your local CANYCOM dealer or our company's sales department regarding service orders or any questions or problems that may arise when using this Product. Please make sure to have the product name, serial number, and the make and type of the engine handy at the time of contact. The model and serial number can be found on the model label as shown below, and the make and type of the engine can be found in Chapter3 "Specifications" of this manual (Page 23).

Location of Model Label

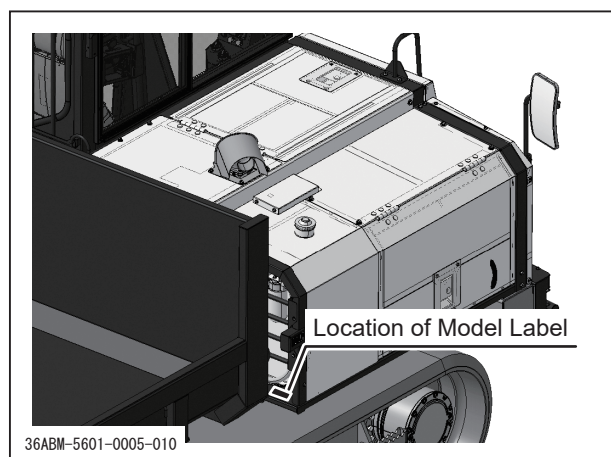

Model Label

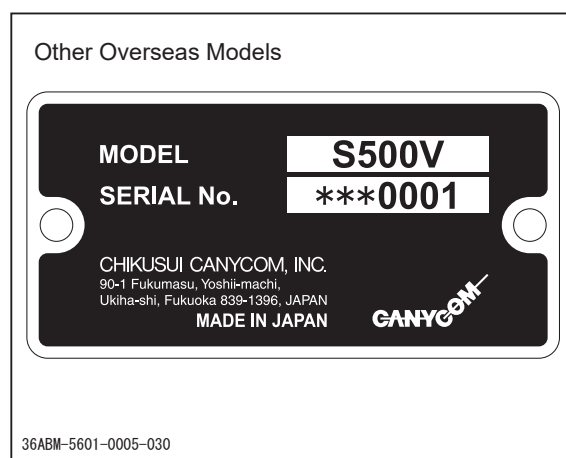
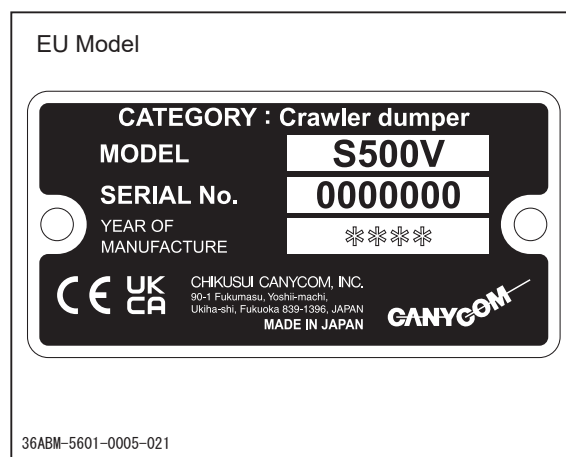

Availability of Spare Parts

The replacement or repair parts for this Product shall remain available for nine years after the production of this type of Product is discontinued.

Contents

1. Safety	1
Safety Labels	1
Safety Mechanisms	12
Safety Precautions	13
Training	13
Preparation	14
Operation	15
Servicing	20
2. Controls and Components	21
Name and Function of Controls	21
3. Specifications	29
Product Specifications	29
Contents of Tool Bag	31
4. Operation	32
Preparation	32
Pre-start up Inspection	32
Checking and Filling Fuel	32
Adjusting Seat	33
Adjusting Mirrors	34
Using Seat Belt	34

Driving	35
Starting	35
Driving	39
Stopping	42
Emergency Stop	43
Parking	44
Working	46
Dumping	46
Using Safety Prop	47
Emergency Dump Valve	48
Cabin	49
Air Conditioner	49
Emergency Equipments	50
Warning Buzzer	51
Operating LCD - LCD1	52
Switches	52
Contents of Home Screen	53
Maintenance Mode Screen	55
Current Error Screen	56
Previous Error Log Screen	58
Settings Screen	59
Data Display Screen	61
Operating LCD -LCD2	66
Home Screen	66
Settings Screen	67

5. Maintenance	68
-----------------------	-----------

Maintenance Schedule	68
Fluids and Lubricants	73
Greasing Points	73

Consumables and Spares	75
Body Panels	76
Maintenance Ladder	76
Engine Hood	77
Side Service Door	78
Side Covers	78
Engine Room Rear Grill	79
Operator Side Service Panel	80
Radiator Fan Shroud	80
Engine	81
Engine Oil	81
Oil Filter	82
Air Cleaner	83
Coolant	84
Fan Belt	86
DPF Regeneration	86
Urea SCR (Selective Catalytic Reduction) System	89
Fuel System	92
Fuel Filter Cartridge	92
Bleeding Air in the Fuel System	93
Draining Water Separator	93
Draining Water From Fuel Tank	95
Drive Train	96
Tracks	96
HST (Hydrostatic Transmission) Oil	99
Travel Motor Oil	102
Compressor Belt	103
Cabin	104
Cleraning Mirrors and Cameras	104

Electrical System	105
Battery	105
Fuses	108
Slow Blow Fuses	110
Lights	111
Air Conditioner (AC) Unit	111
After Use Care	112
After Normal Use	112
After Cold Weather Use	112
Washing	113
Storage	114

6. Troubleshooting **116**

Troubleshooting	116
-----------------------	-----

7. Transporting **122**

Hauling	122
Loading and Unloading	122
Hoisting and Towing	124
Hoisting	124
Towing	125

Appendix

- Operator's Manual for the Engine
 - Audio Manual
 - Around View Camera Manual
 - Be sure to read and understand it together with this manual.
-

Safety Labels

The safety labels shown in the next pages are attached to the machine. See the illustration in the following pages for the location and the content of each label on the machine.

- **Locate all the warning labels attached to this machine. Read and follow the instructions and precautions in them. Failure to do so could result in serious injury or death to the operator or bystanders.**
- **Keep the labels clean and legible. Do not use solvents or gasoline to clean the labels.**
- **Replace these labels immediately if they have been removed, have fallen off or become illegible. Use the part number, on the label or shown in this manual, to order a replacement label from your CANYCOM representative.**

EU Model

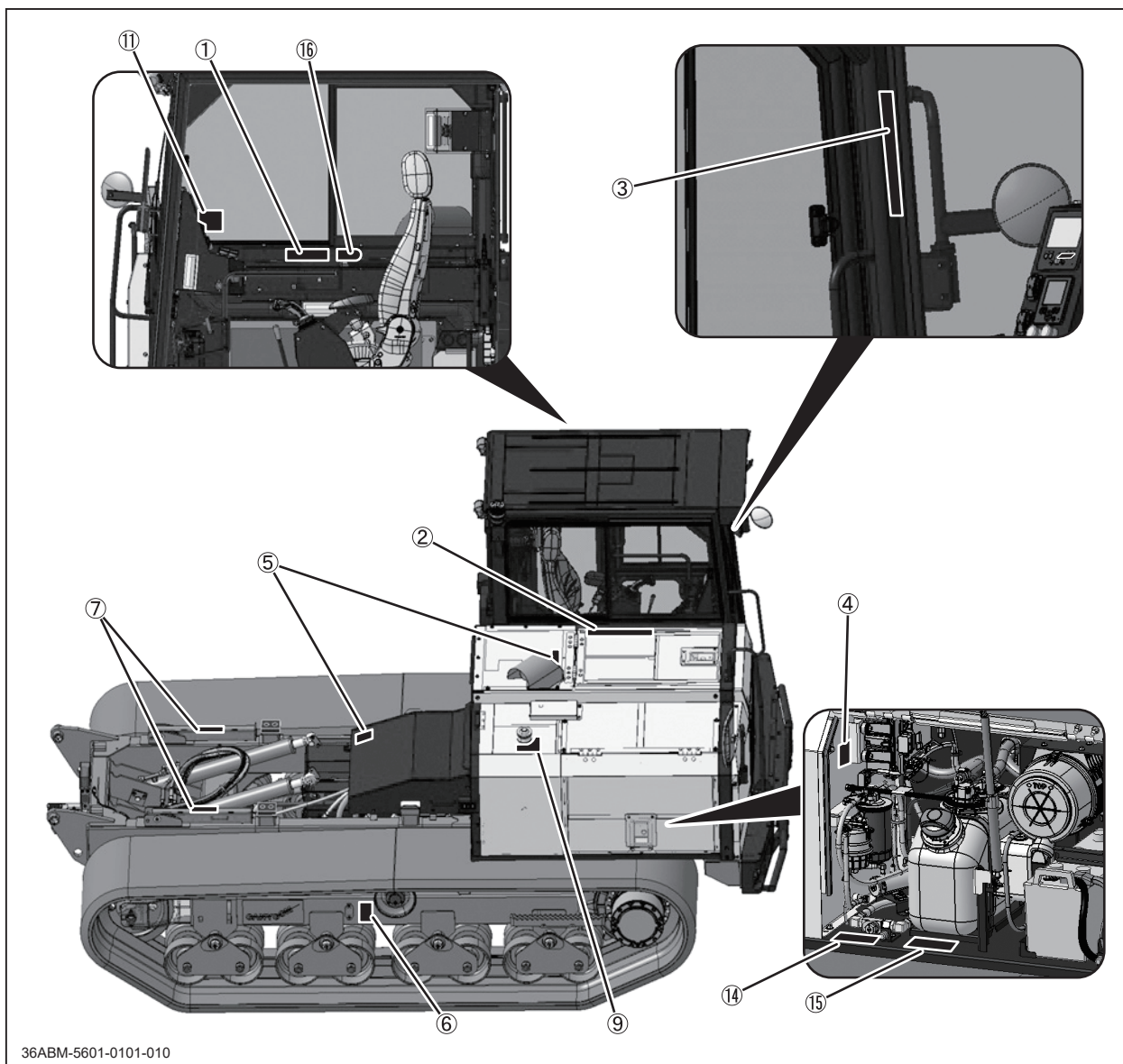

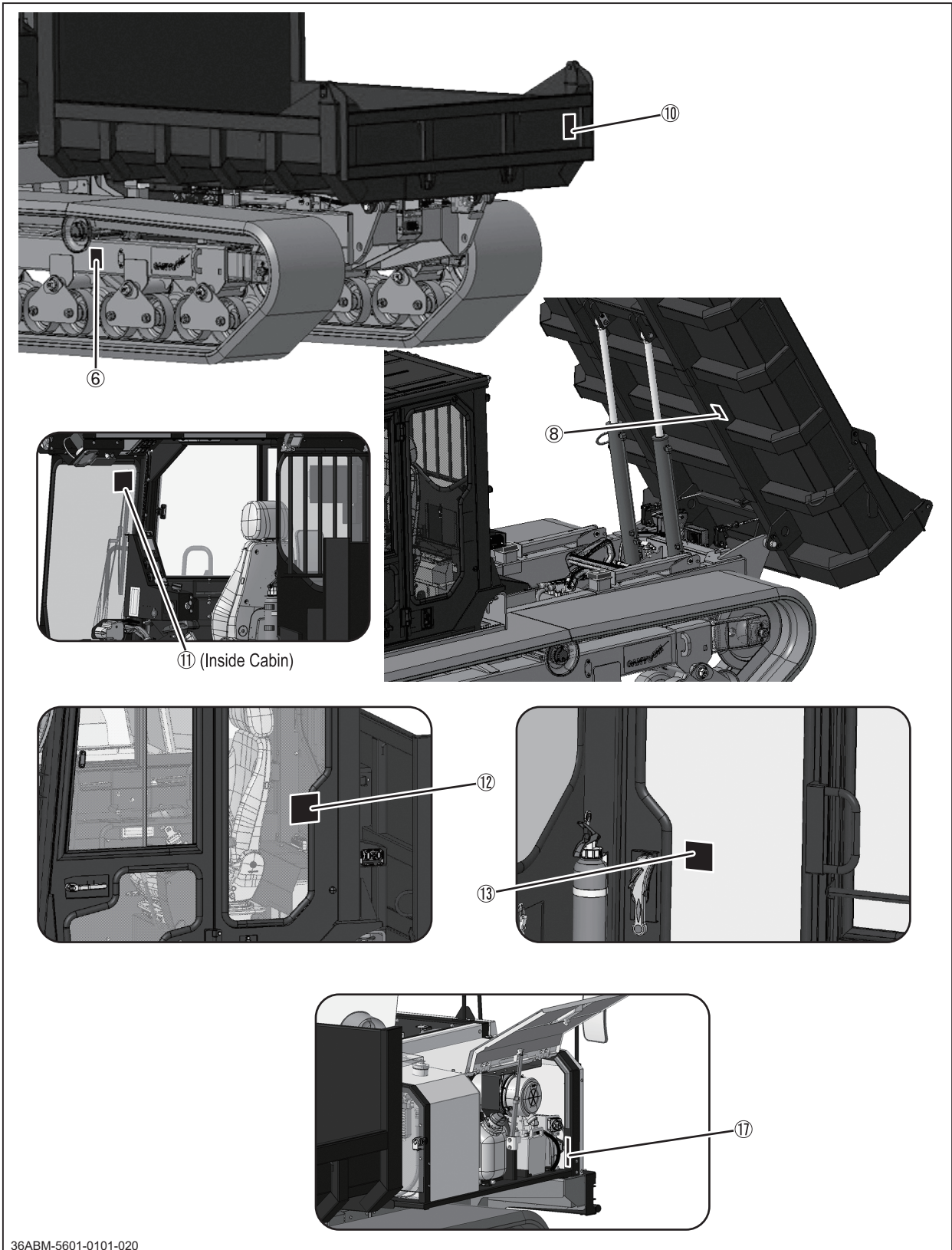

① 36AB 5036 000

Turbo Protection Function

When the engine is cold, the engine speed is controlled to prevent seizure due to lack of lubrication.

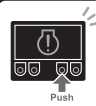

If an error appears on the Liquid Crystal Display (LCD) press the button and check the error code.



Manual DPF (Diesel Particulate Filter) Regeneration

Manual DPF regeneration takes 15 to 20 minutes. If any of the items displayed on the LCD are not met, the process will be canceled. Please refer to the instruction manual for more details.



HFC R134a
0.62±0.05kg
GWP : 1430

Teq_{CO2} = 0.887 tons

36AB 5036 000

② 36AA 5029 000

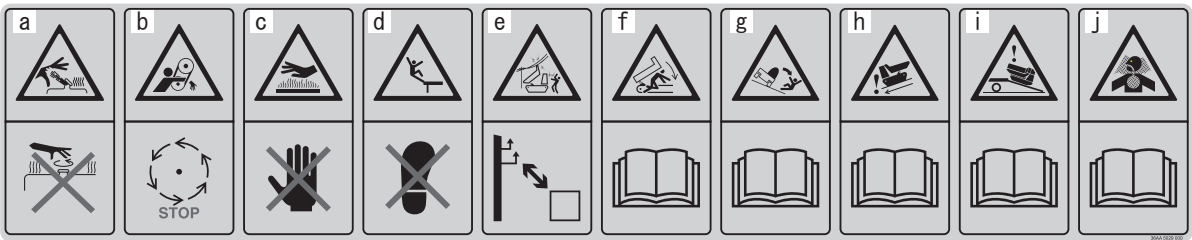

③ 36AA 5031 000

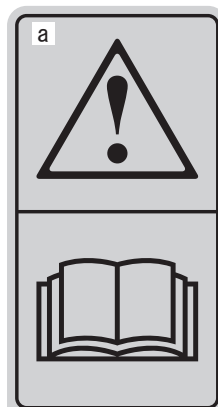

④ 36AA 5032 000

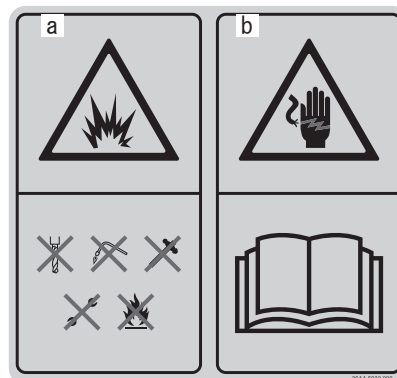

⑤ 3667 5063 000



⑥ 5229 5116 000



⑦ 36AA 5009 001



⑧ 3667 5066 000



⑨ 36AB 5037 000



**Diesel Fuel
Only**

1. 36AB 5036 000
 - a. Regenerate DPF manually when DPF regen is requested. Malfunction can result.
 - b. Fire hazard. When regenerating DPF, make sure that there are no combustible materials around the exhaust pipe.
 - c. Carbon monoxide poisoning hazard. Do not start the engine in an enclosed area.

2. 36AA 5029 000
 - a. Radiator - burn hazard. Do not remove the cap when the engine or the radiator is hot.
 - b. Entanglement hazard. Stop the engine when servicing.
 - c. Burn hazard. The surface gets hot. Do not touch this surface when it is hot.
 - d. Fall hazard. Do not step on this area.
 - e. Beware of the overhead electric lines when dumping. Take a sufficient distance.
 - f. Crush hazard. Read the operator's manual and take the necessary precautions (i.e. to apply the safety prop) when servicing under the vessel.
 - g. Put the load evenly in the vessel.
 - h. Drive slow on downhill. Lower the engine speed and drive slowly when carrying load.
 - i. Follow the precautions for loading this machine onto or unloading it from a transporter. Use an appropriate set of loading ladders and drive slowly.
 - j. Do not start the engine in an enclosed area.

3. 36AA 5031 000
 - a. Read the Operator's manual regarding the use of the ROPS/FOPS. Check the condition of the ROPS/FOPS and seatbelt before use. If the ROPS/FOPS has been subject to a rollover/fallover accident, replace it..
 - b. Rollover hazard. Wear seatbelt when operating this machine.

4. 36AA 5032 000
 - a. Fuel tank - fire and explosion hazard. Do not drill, or torch, subject to impact or open flame.
 - b. Shock hazard. Read the related sections of the operator's manual before servicing.

5. 3667 5063 000

Burn hazard. The surface gets hot. Do not touch this surface when it is hot.

6. 5229 5116 000

The grease nipple is under pressure and can be ejected off. When adjusting the track tension, follow the instruction in the operator's manual to depressurize the cylinder, by turning it less than one turn.

7. 36AA 5009 001
Crush hazard. Apply safety prop when working under the vessel.
8. 3667 5066 000
Crush hazard. Read manual before working under the vessel.
9. 36AB 5037 000
Explosion hazard. Keep fire away.

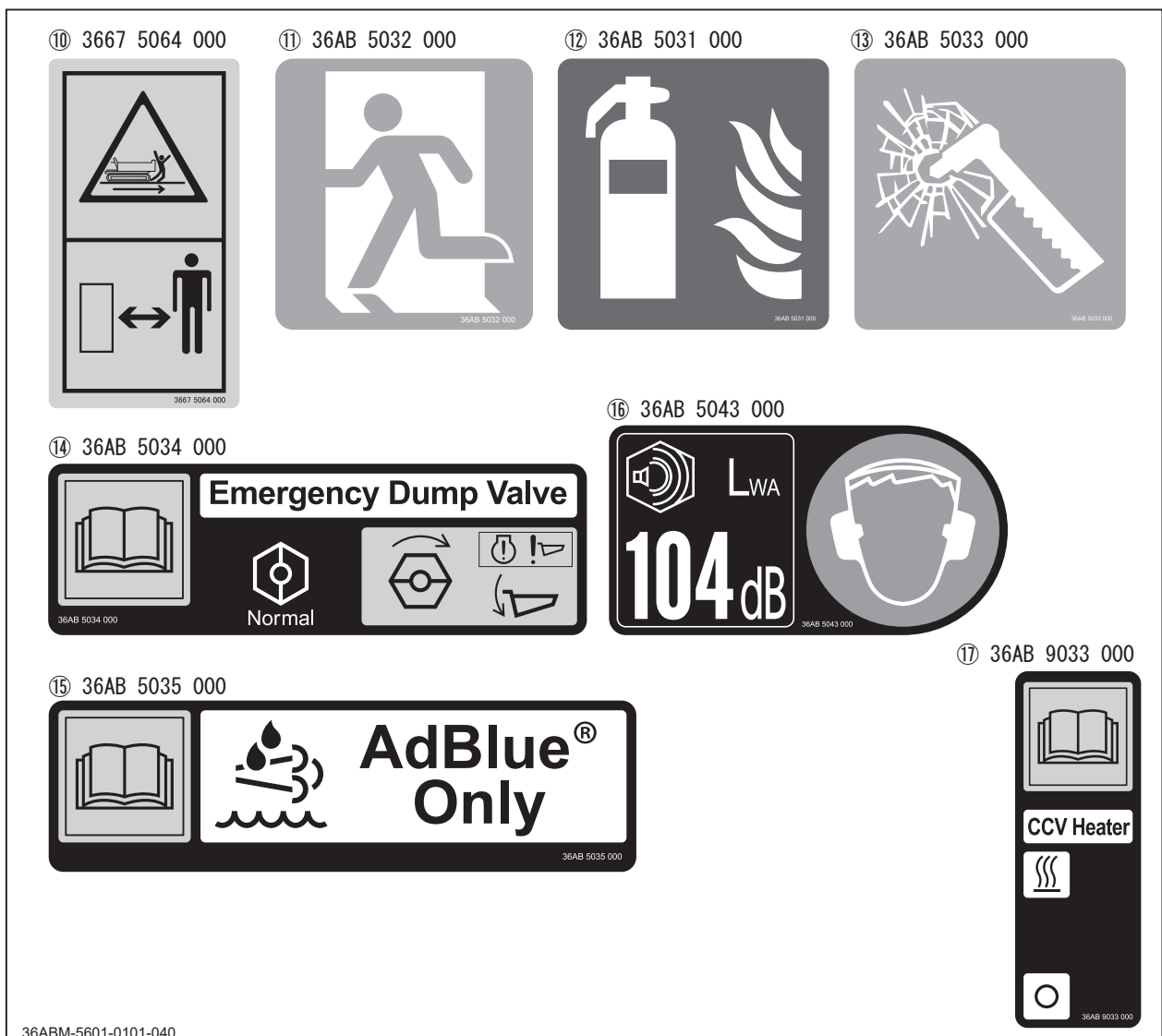

10. 3667 5064 000
Run over hazard. Stay away from the back of the machine. The machine can back up unexpectedly.

11. 36AB 5032 000
Emergency exit. Escape from the cabin in case the door cannot be opened.
12. 36AB 5031 000
Fire extinguisher location. Use this fire extinguisher in case of fire.
13. 36AB 5033 000
Hammer location location. Use this hammer to break the window if you are trapped in the cabin.
14. 36AB 5034 000
Emergency dump valve. Read manual for instruction.
15. 36AB 5035 000
AdBlue tank. Read manual when filling AdBlue.
16. 36AB 5043 000
Wear earmuffs when operating this machine.
17. 36AB 9033 000
Before using the CCV (Closed Crankcase Ventilation) heater, read the operator's manual for its operation (page 20).



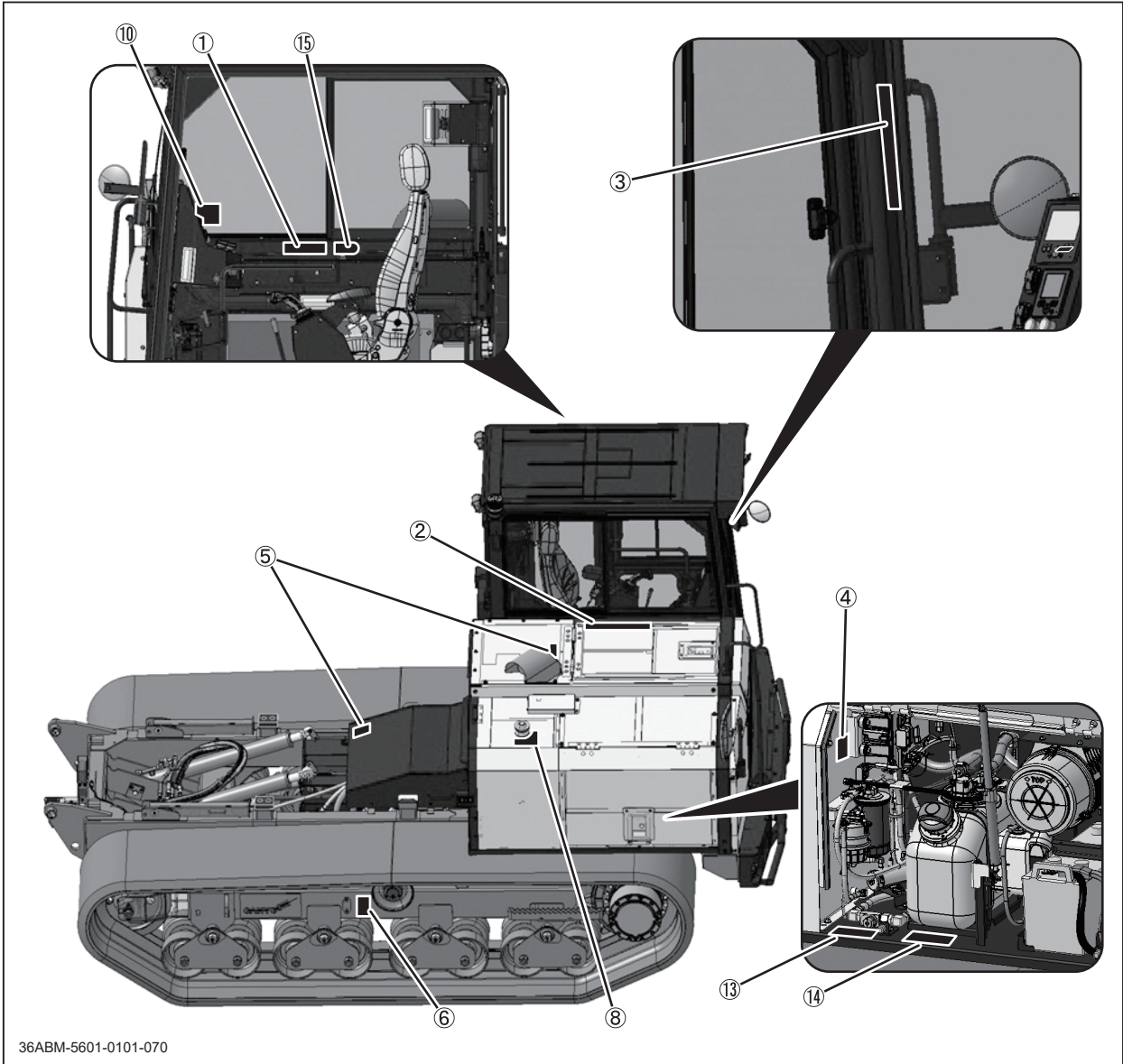

US Model

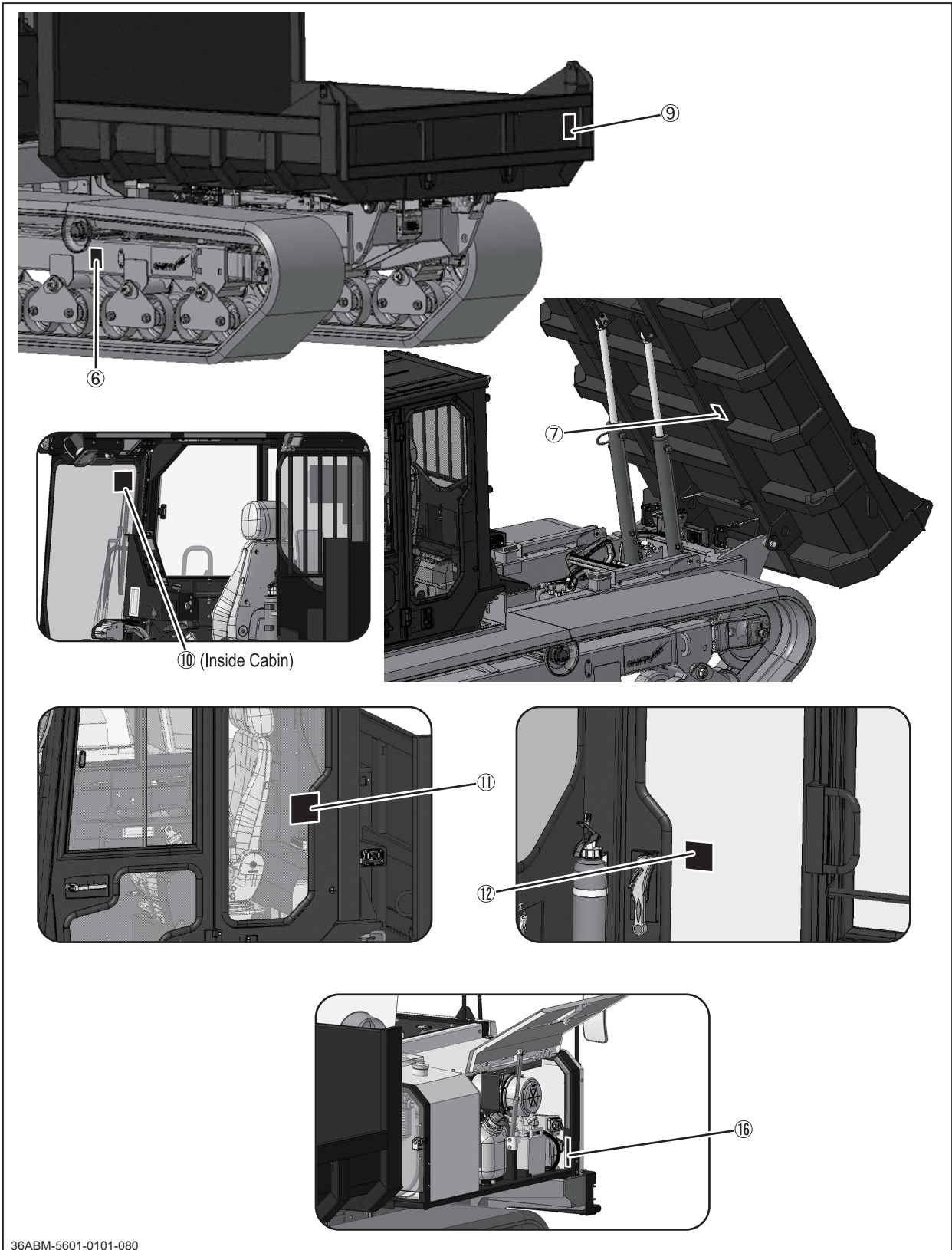











36ABM-5601-0101-070



① 36AB 5058 000

<p>WARNING</p>  <p>Turbo Protection Function</p> <p>When the engine is cold, the engine speed is controlled to prevent seizure due to lack of lubrication.</p> <p>Read manual for instruction.</p>	<p>WARNING</p>  <p>Push</p> <p>If an error appears on the Liquid Crystal Display (LCD) press the button and check the error code.</p>	<p>Manual DPF (Diesel Particulate Filter) Regeneration</p> <p>Manual DPF regeneration takes 15 to 20 minutes. If any of the items displayed on the LCD are not met, the process will be canceled. Please refer to the instruction manual for more details.</p>	<p>CAUTION</p>  <p>Regenerate DPF manually when DPF regen is requested. Malfunction can result.</p>	<p>WARNING</p>  <p>Fire hazard. When regenerating DPF, make sure that there are no combustible materials around the exhaust pipe.</p>	<p>WARNING</p>  <p>Carbon monoxide poisoning hazard. Do not start the engine in an enclosed area.</p>	<p>HFC R134a 0.62±0.05 kg GWP : 1430</p> <p>Teq_{CO2} = 0.887 tons</p>
---	---	---	---	---	---	--

② 36AB 5059 000

<p>a WARNING</p>  <p>Radiator - burn hazard. Do not remove the cap when the engine or the radiator is hot.</p>	<p>b WARNING</p>  <p>Entanglement hazard. Stop the engine when servicing.</p>	<p>c WARNING</p>  <p>Burn hazard. The surface gets hot. Do not touch this surface when it is hot.</p>	<p>d WARNING</p>  <p>Fall hazard. Do not step on this area.</p>	<p>e WARNING</p>  <p>Beware of the overhead electric lines when dumping. Take a sufficient distance.</p>	<p>f WARNING</p>  <p>Crush hazard. Read the operator's manual and take the necessary precautions (i.e. to apply the safety prop) when servicing under the vessel.</p>	<p>g WARNING</p>  <p>Put the load evenly in the vessel.</p>	<p>h WARNING</p>  <p>Drive slow on downhill. Lower the engine speed and drive slowly when carrying load.</p>	<p>i WARNING</p>  <p>Follow the precautions for loading this machine onto or unloading it from a transporter. Use an appropriate set of loading ladders and drive slowly.</p>	<p>j WARNING</p>  <p>Do not start the engine in an enclosed area.</p>
--	---	---	---	--	---	--	--	---	---

③ 36AB 5061 000

a WARNING

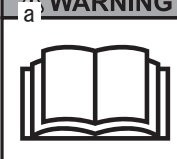

Read the Operator's manual regarding the use of the ROPS/FOPS. Check the condition of the ROPS/FOPS and seatbelt before use. If the ROPS/FOPS has been subject to a rollover/fallover accident, replace it.

b WARNING



Rollover hazard. Wear seatbelt when operating this machine.

④ 36AB 5062 000

a DANGER



Fuel tank - fire and explosion hazard. Do not drill, or torch, subject to impact or open flame.

b WARNING



Shock hazard. Read the related sections of the operator's manual before servicing.

⑤ 36AB 5063 000

WARNING



Burn hazard. The surface gets hot. Do not touch this surface when it is hot.

⑥ 36AB 5064 000

WARNING



Track adjuster valve can fly off. Adjuster cylinder is under pressure. Loosen valve for less than one turn to release pressure before removing.

⑦ 36AB 5066 000

DANGER



Crush hazard. Read manual before working under the vessel.

⑧ 36AB 5055 000

DANGER



Diesel Fuel Only

Explosion hazard. Keep fire away.

1. 36AB 5058 000
 - a. Regenerate DPF manually when DPF regen is requested. Malfunction can result.
 - b. Fire hazard. When regenerating DPF, make sure that there are no combustible materials around the exhaust pipe.
 - c. Carbon monoxide poisoning hazard. Do not start the engine in an enclosed area.

2. 36AB 5059 000
 - a. Radiator - burn hazard. Do not remove the cap when the engine or the radiator is hot.
 - b. Entanglement hazard. Stop the engine when servicing.
 - c. Burn hazard. The surface gets hot. Do not touch this surface when it is hot.
 - d. Fall hazard. Do not step on this area.
 - e. Beware of the overhead electric lines when dumping. Take a sufficient distance.
 - f. Crush hazard. Read the operator's manual and take the necessary precautions (i.e. to apply the safety prop) when servicing under the vessel.
 - g. Rollover hazard. Put the load evenly in the vessel.
 - h. Drive slow on downhill. Lower the engine speed and drive slowly when carrying load.
 - i. Follow the precautions for loading this machine onto or unloading it from a transporter. Use an appropriate set of loading ladders and drive slowly.
 - j. Do not start the engine in an enclosed area.

3. 36AB 5061 000
 - a. Read the Operator's manual regarding the use of the ROPS/FOPS. Check the condition of the ROPS/FOPS and seatbelt before use. If the ROPS/FOPS has been subject to a rollover/fallover accident, replace it..
 - b. Rollover hazard. Wear seatbelt when operating this machine.

4. 36AB 5062 000
 - a. Fuel tank - fire and explosion hazard. Do not drill, or torch, subject to impact or open flame.
 - b. Shock hazard. Read the related sections of the operator's manual before servicing.

5. 36AB 5063 000

Burn hazard. The surface gets hot. Do not touch this surface when it is hot.

6. 36AB 5064 000

The grease nipple is under pressure and can be ejected off. When adjusting the track tension, follow the instruction in the operator's manual to depressurize the cylinder, by turning it less than one turn.

7. 36AB 5066 000
Crush hazard. Read manual before working under the vessel.
8. 36AB 5055 000
Explosion hazard. Keep fire away.

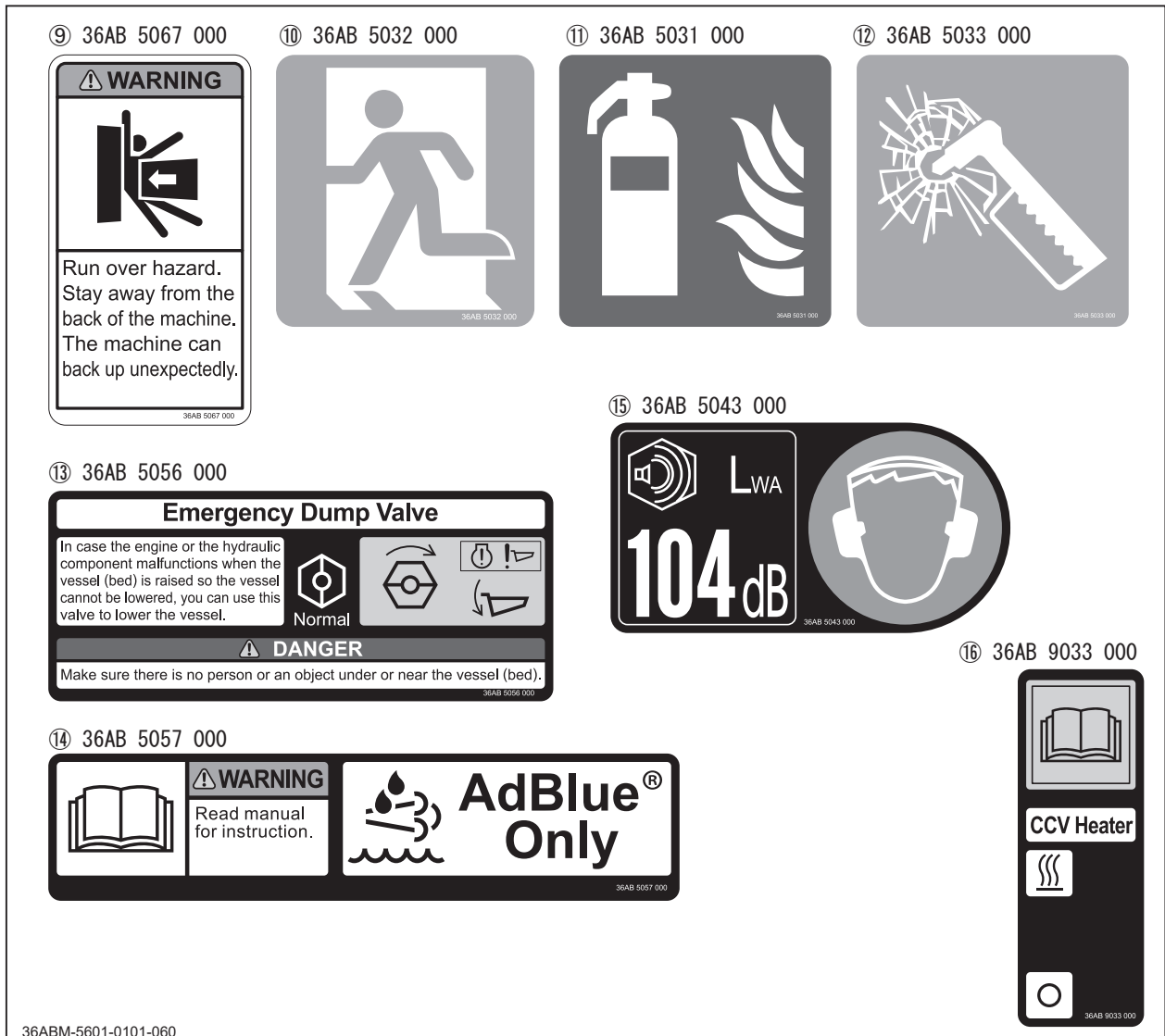

9. 36AB 5067 000
Run over hazard. Stay away from the back of the machine. The machine can back up unexpectedly.
10. 36AB 5032 000
Emergency exit. Escape from the cabin in case the door cannot be opened.

11. 36AB 5031 000
Fire extinguisher location. Use this fire extinguisher in case of fire.
12. 36AB 5033 000
Hammer location location. Use this hammer to break the window if you are trapped in the cabin.
13. 36AB 5056 000
Crush hazard. Make sure nobody is near or under the vessel when operating the Emergency dump valve. Read manual for instruction.
14. 36AB 5057 000
AdBlue tank. Read manual when filling AdBlue.
15. 36AB 5043 000
Wear earmuffs when operating this machine.
16. 36AB 9033 000
Before using the CCV (Closed Crankcase Ventilation) heater, read the operator's manual for its operation (page 20).

Safety Mechanisms

This product is equipped with the following safety mechanisms.

Emergency Engine Stop

When the machine is tilted over 60 degrees in any direction for more than 3 seconds, the engine is stopped. (See page 42).

Rollover Warning Buzzer

The rollover warning buzzer warns when the machine is tilted over certain angles. At 20 degrees, it beeps intermittently. At 27.5 degrees, it beeps repeatedly.

Vessel Angle Warning and Speed Limiter

When the vessel is raised more than 3 degrees, vessel angle warning is lit up in the LCD 2, and the top travel speed is limited to 9km/h.

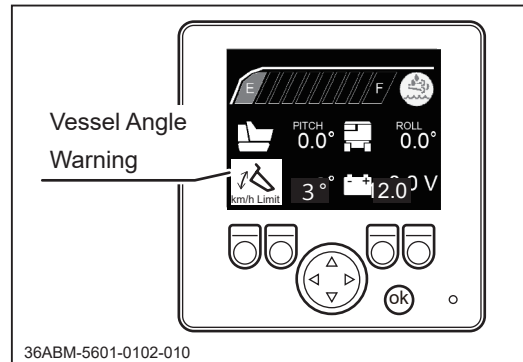

Other Safety-related Equipments

This machine is also equipped with a fire extinguisher for initial firefighting, and a hammer for braking the cabin window in case the operator is trapped inside the cabin.

Safety Precautions

This section contains safety precautions to follow when operating and maintaining the machine. Read and understand the precautions in this section as well as throughout this manual and follow them when operating or maintaining the machine. Failure to follow safety precautions could result in property damage, serious injury or death to the operator or bystanders.

Training

All operators and mechanics should receive practical instructions from their employer or renter. Such instructions should cover the following issues:

- **It is essential to familiarize yourself with the controls, safety labels and the proper use of the machine.**
- **Never allow people unfamiliar with these instructions to operate or service the machine. Do not let anyone under 18 years of age to operate this machine. Local regulations may restrict the minimum age for operating the machine. Consult your local authority.**
- **The operator is responsible for the accidents or hazards caused to other people or their property.**

- This machine has a riding capacity for one person only. Do not carry passengers other than the operator.
- Always keep in mind that care and concentration is required when working with ride-on machines.
- Loss of control on a slope cannot be regained by the application of the brake. The main reasons for loss of control are:
 - insufficient grip of tracks.
 - excessive speed.
 - misjudging of the ground conditions, especially slopes.
 - excessive load.
 - incorrect distribution of load.

Preparation

WARNING

- Fuel is highly flammable. See Checking Fuel, page 32, for important safety information on handling fuel.

- Always wear protective footwear, long trousers, hardhat, safety glasses and ear protection when operating or servicing the machine. Proper clothing will minimize the chance of injury. Do not operate the equipment if you have long hair, loose clothing, or jewelry; all of which can get tangled in the moving parts. Do not operate the machine barefoot or with open sandals.
- Prepare beforehand the working rules and procedures such as signaling and traffic control for the work place. Following such rules will reduce the risk of accidents.
- Never handle fuel or grease, service the engine, or recharge the battery in the presence of fire or spark.
- Perform the daily pre-startup inspection (see Preparation, page 32) before starting the machine. Repair or replace damaged parts before starting the machine.

Operation

This machine is intended for carrying sand and dirt. Carrying other materials can damage the machine. Avoid carrying liquid concrete. That will damage the machine.

The stability of the machine is affected by the speed, rate of steering, terrain and the load. Always pay close attention to these factors or a loss of control or tip over could occur, resulting in property damage, serious injury or death.

General Driving

- **Do not operate the engine in a confined space where dangerous carbon monoxide fumes can accumulate.**
- **Do not touch the engine, muffler or exhaust pipe while the engine is running or soon after it has stopped. These areas will be very hot and can cause burns.**
- **Do not operate the machine under the influence of alcohol or drugs. Do not operate the machine when you are tired, ill, or not feeling well.**
- **Always check for obstacles before operating on new terrain.**
- **Before starting the engine and moving the machine, scan around your surroundings and make sure all persons and other vehicles are a safe distance away from the machine. Sound the horn to warn bystanders.**
- **On the machine equipped with the ROPS, always wear the seat belt when in use.**
- **Always stay seated in the operator's seat when driving the machine. Never operate the travel lever off of the machine.**
- **On a slippery surface, travel slowly and exercise caution to reduce the chance of skidding or sliding out of control. Never operate on ice.**
- **Always make certain that there is no obstacle or a person behind the machine when backing up. Check your surroundings with the rear view mirrors and Around View as necessary. After confirming that it is safe to back up, move slowly and avoid sharp turns.**

- To reduce the risk of tip over, pay special attention when encountering an obstacle or a slope, or when braking on a slope or during a turn. See **Driving on a Slope** on the next page.
- Never attempt to drive over a large obstacle such as rock or fallen tree.
- Always travel slowly and use extra caution when operating on unfamiliar terrain. Be alert when traveling on changing terrain.
- Never operate on terrain that you are not comfortable with. Avoid terrain that is so rough, slippery or loose that you feel like you could tip over.
- Do not operate the machine near the edge of a cliff, an overhang or a slide area.
- Do not make sudden maneuvers. A sudden start, stop, or turn can make the machine lose control and could cause a tip over. Be especially cautious when traveling on soft or wet ground.
- Drive at a safe speed, taking into account the surface gradient, surface conditions and load.
- Use an observer to help direct the machine when the visibility is poor, terrain is rugged or hilly, or maneuvering room is limited. The observer should be able to see the machine and its immediate surroundings, and should give pre-arranged signals to direct the operator.
- Do not use this machine in puddle or mud deeper than its ground clearance. Water or mud can enter the exhaust pipe or electrical components and damage the machine.
- Wash the machine after use in wet or muddy condition and grease up the grease points.

Driving on a Slope

WARNING

- Never use on a slope steeper than 25 degrees.
 - Driving on a slope can be dangerous. It can result in a tip over and cause serious injury or death. Take the following precautions.
-
- Always follow proper procedures for driving on a slope as described in this manual.
 - Driving on a slope in a wrong manner can cause a loss of control or a vehicle tip over. Check the terrain carefully before attempting to drive on a slope.
 - Observe the stability angles of the machine as stated in the label on the machine. The figures are the maximum values; avoid using the machine near these figures.
 - The angle of inclination of this machine is indicated in the LCD monitor. If the angle reaches 25 degrees, the symbol and the letters on the display change color. When that happens, immediately move to a location with a gentler slope.
 - Never drive on a slope that you are not comfortable with. Avoid a slope that is so rough, slippery, or loose that you feel like you could tip over.
 - When driving up a slope, proceed at a steady rate of speed and accelerator position.
 - Never move the accelerator lever or the travel lever suddenly.
 - If the engine stalls or loses traction during a climb and cannot make it to the top of the slope, do not try to turn the machine around. Carefully back down slowly, straight down the slope.
 - Drive straight up or down slopes. Avoid turning on a slope.
 - When going over the top of a slope, go slow; an obstacle, a sharp drop, or another vehicle or person could be on the other side of the crest.
 - Avoid driving the machine across a slope.

- Without a load, drive the machine backwards up a slope (operator's seat toward the top) when climbing, and drive it forward when going down a slope.
- With a load, drive the machine forward up a slope (operator's seat away from the top) when climbing, and drive it backwards when going down a slope. Be especially cautious when operating on a slope with a load.
- When driving down a slope, use the travel lever so that the machine travels down at the minimum speed. Use the engine speed to help keep the machine speed low.

Loading and Driving with a Load

- The maximum payload for this machine is 5000 kg. Do not exceed this maximum payload under any circumstance.
- Do not operate on a slope steeper than 20 degrees when carrying a load. Do not carry more than 2500 kg when operating on a slope between 15 and 20 degrees.
- Load cargo in the bucket so the weight is evenly distributed. When carrying a cargo, strap the cargo to the bucket to prevent the cargo from shifting. Ensure that cargo does not obstruct the operator's field of view.
- When carrying a load, drive at a reduced speed. Allow a greater distance for braking.
- Before crossing a bridge or an overpass, make certain that the total combined weight of the machine, the load and the driver is within the stated weight limit for the bridge or the overpass. Then, proceed carefully and at a constant speed.

Dumping

When dumping material from the bucket, take the following precautions.

- Always follow the proper procedures for dumping as described in this manual.
- Only operate the bucket with the engine running.
- Always stay seated in the operator's seat when dumping the bucket. Never operate the operation lever off of the machine.

- Perform the dump operation on a flat, level and stable surface whenever possible. Raising or lowering the bucket on a slope or rough terrain could result in a tip over.
- Weight can shift when dumping. Pay attention to the vehicle balance and dump carefully.
- Make certain that all persons are at a safe distance away from the machine when raising or lowering the bucket.
- Do not move the machine or leave it unattended with the bucket in the raised position.
- Engage the bucket safety prop if you must place any part of your body under the bucket in the raised position.

Parking

- Park the machine on a flat, level and stable surface. Never park on a slope steeper than 15 degrees. Avoid parking on a slope less than 15 degrees. If parking on a slope less than 15 degrees is unavoidable, apply the parking brake and block the tracks at the lower end of the machine.
 - Without a load, park the machine with the operator's seat facing downhill
 - With a load, park the machine with the operator's seat facing uphill
 - Do not park sideways on a slope.
- Observe all the previous precautions for driving, driving on a slope, loading and driving with a load, and dumping.
- Whenever you park the machine, apply the parking brake and stop the engine. Remove the key whenever you leave the machine unattended to prevent unauthorized use or accidental starting.
- Diesel fuel is flammable and can be explosive. When parking the machine indoors, make certain that the building is well ventilated and that the machine is not close to any source of flame or spark, including appliances with pilot lights.

Servicing

- **Do not service the machine when the engine is running. If it is absolutely necessary to run the engine while servicing, pay attention to the moving parts; keep hands, feet, clothing and any part of the body away from any moving part, especially the cooling fan and the belts at the side of the engine.**
- **Do not operate the engine in a confined space where dangerous carbon monoxide fumes can accumulate.**
- **Make sure all hydraulic line connectors are tight and all hydraulic hoses and lines are in good condition and leak-free before applying hydraulic pressure to the system.**
- **Keep your body and hands away from pinhole leaks or nozzles that eject hydraulic fluid under high pressure. Use paper or cardboard, not your hands, to search for leaks. Hydraulic fluid escaping under pressure can have sufficient force to penetrate the skin and cause serious injury.**
- **Check all fuel lines on a regular basis for tightness and wear. Tighten or repair them as needed.**
- **Do not touch the engine, muffler, DPF, or exhaust pipe while the engine is running or soon after it has stopped. These areas will be very hot and can cause burns.**
- **The engine must be shut off before checking or adding oil.**
- **In case the cab frame is deformed or damaged as a result of rollover or clash, replace the entire cabin.**
- **Follow the local laws and regulations when scrapping this machine.**

Name and Function of Controls

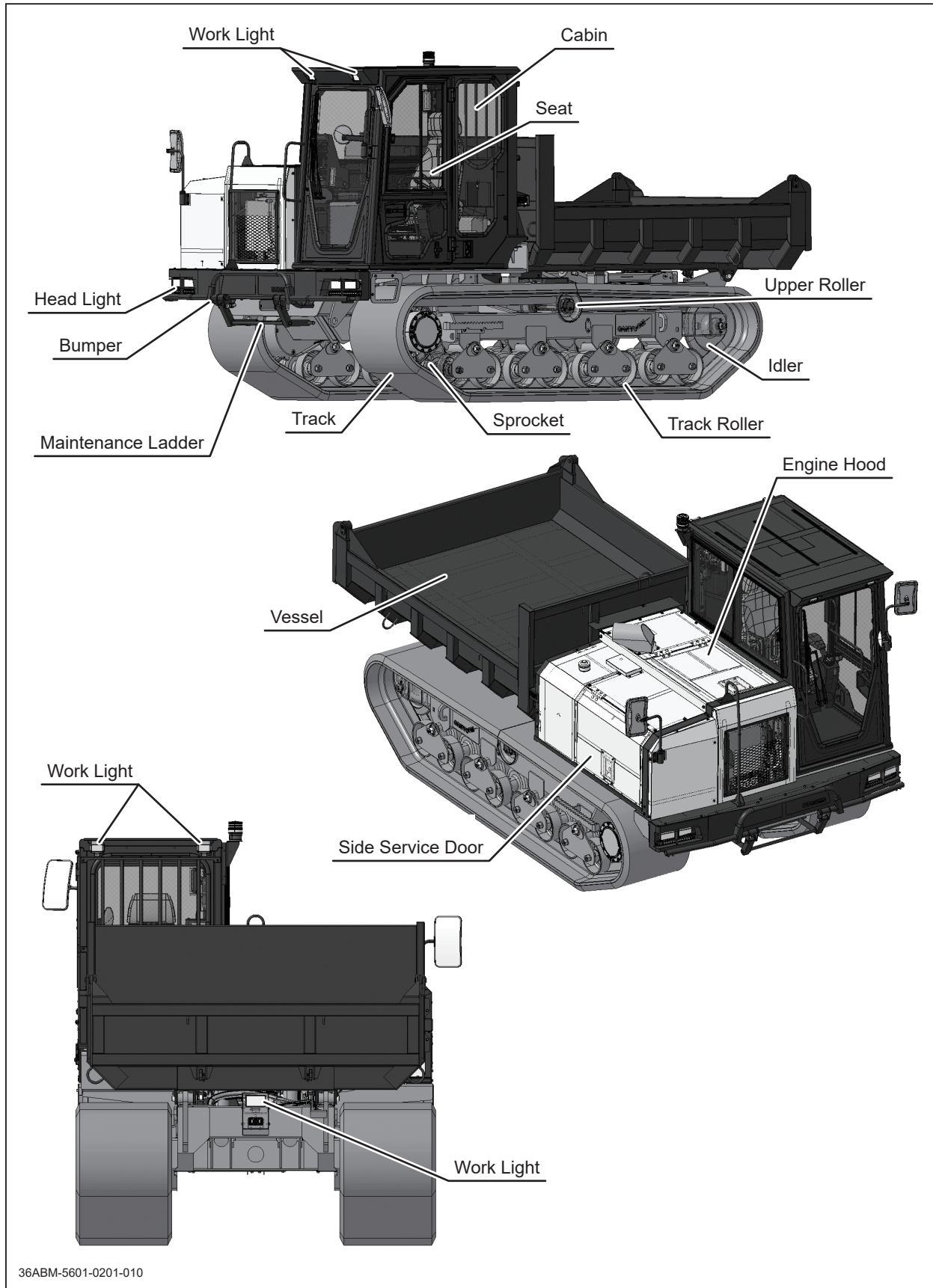

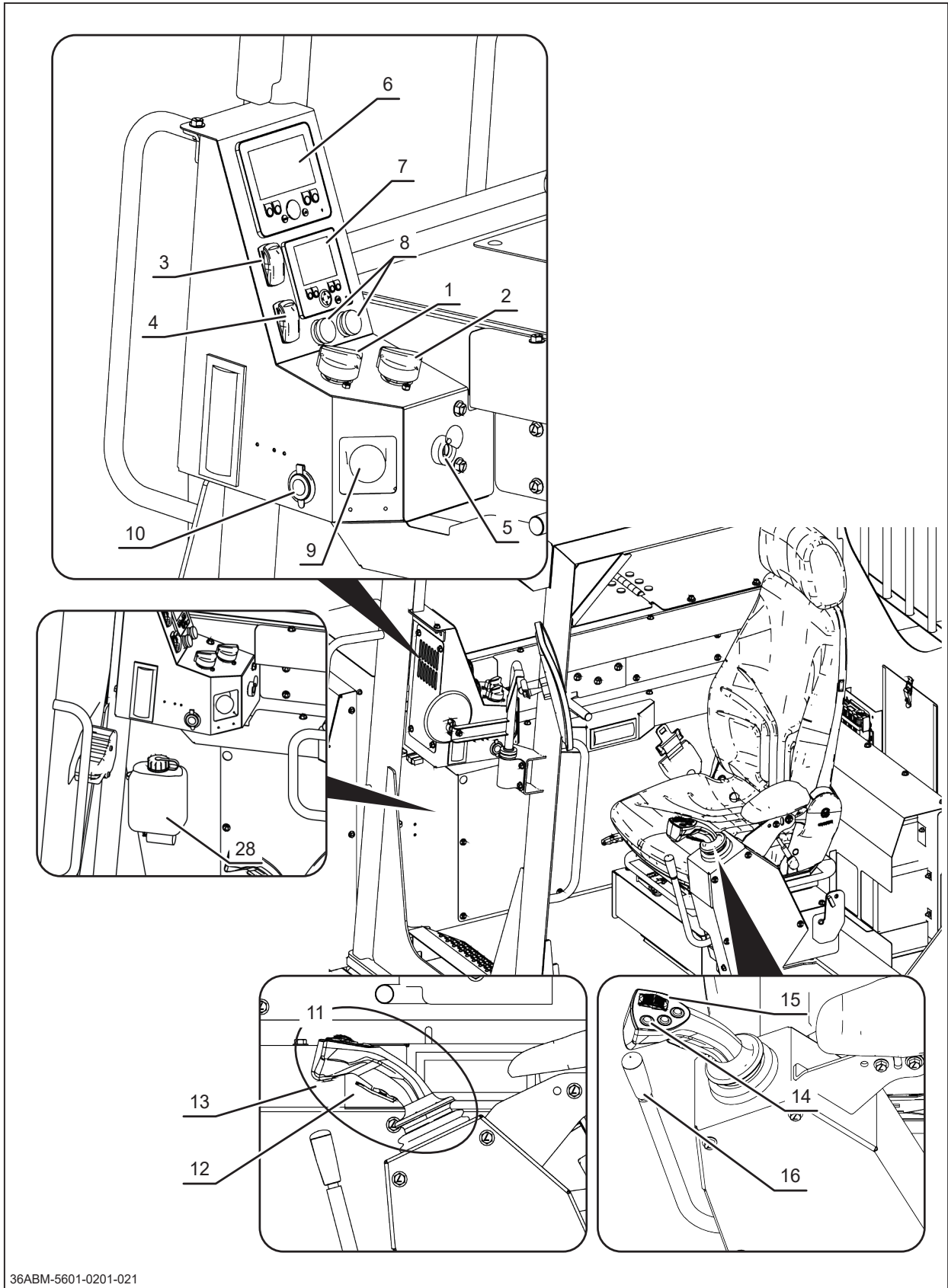

36ABM-5601-0201-021

1. **Accelerator Knob** These increase or decrease the engine speed.
2. **Speed Knob** This is used to set the maximum travel speed.
3. **H/L Speed Selector Switch** This is used to switch the travel speed between [HI] and [LO].
4. **Parking Brake Switch.** This is used when parking the machine. (When the parking brake switch is at the (P) position, the machine does not move even when the travel lever is operated.)
5. **Main Switch.** This is used to start or stop the engine.
6. **LCD Display 1** This shows fuel level, coolant temperature, the cumulative total operating time of the machine, etc.
7. **LCD Display 2** This shows urea level, tilt angle of the machine, battery voltage, etc.
8. **Turn Signal Buttons** These are used to turn on the turn signal on either side. When both buttons are pressed at once, they work as the hazard lamp.
9. **Emergency Switch** Pressing this switch kills the engine in case of emergency.
10. **USB Socket** This is used to provide electricity. (Type A: QC 3.0, Type C: PD 18W)
11. **Travel Lever** This is used when changing the direction of travel (FORWARD or REVERSE) or when turning the machine.
12. **Trigger Switch.** This switch needs to be pressed and the travel lever tilted for the machine to travel. This switch is also used for neutral check operation before traveling.
13. **Horn Switch** Pressing this switch sounds the horn.

- 14. Spin Turn Switch** Pressing this switch and tilt the travel lever to a side to spin-turn the machine.
- 15. Dump Switch.** Pushing this switch downward to raise the dump body, and pushing this switch upward to lower the dump body.
- 16. Lock Lever** Pulling the lock lever up disables the travel lever. This helps the operator to embark to or disembark from the machine.

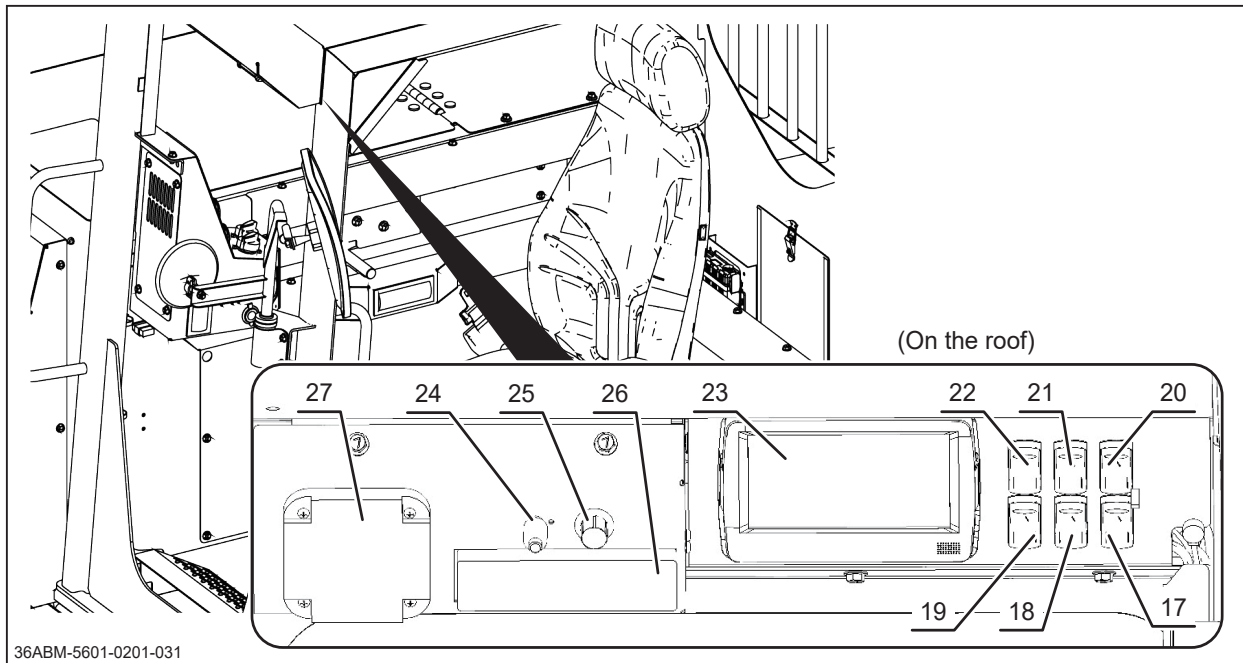

- 17. Light Switch** Pressing this button turns the head lights on.
- 18. Work Light Switch** Pressing this button turns the work lights on.
- 19. ECO Mode Switch** When this switch is pressed, the maximum engine power is restricted to approximately 80% of the maximum. Also when this switch is pressed and the joystick is returned to neutral, the parking brake switch is set to "P", or the lock lever is set to "lock", the engine speed is automatically lowered to low idle.

- 20. **Room Lamp Switch** Pushing this switch to turn on the interior lights.

- 21. **Wiper Switch**. Pressing this switch operates the windshield wiper.

- 22. **Washer Switch** Pressing this switch activates the windshield washer.

- 23. **Around View Monitor**. Shows images from the cameras installed on the left, right and rear sides of the machine. For more details, refer to the separate Around View manual.

- 24. **Air Conditioner Switch** Turns the air conditioner on or off and selects the air speed levels.

- 25. **Air Conditioner** Sets the air temperature from the air conditioner.
Temperature Knob

- 26. **Audio** Radio available. External audio devices can be connected
(Optional) via Bluetooth. For details, refer to the separate audio manual.

- 27. **Speaker** Speaker for the audio.
(Optional)

- 28. **Washer Fluid Tank** This tank contains windshield washer fluid. Refill it when it gets low. (1.2L)

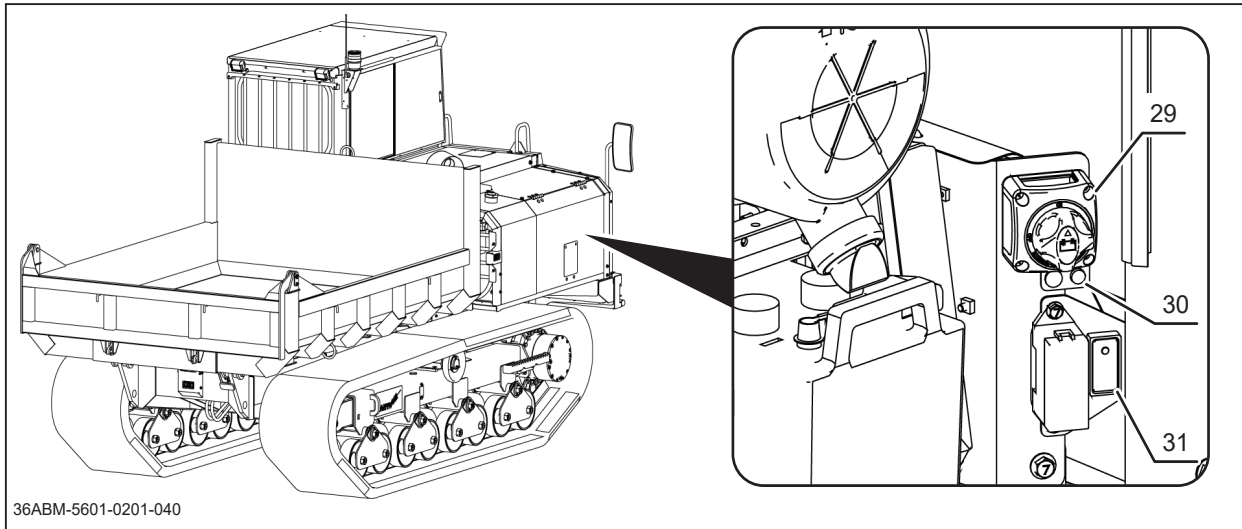

- 29. Battery Cutoff Switch.** This switch connects or disconnects the battery positive circuit for maintenance and long-term storage.
- 30. ACU Indicator Lamp.** ACU indicator lamp indicates the state of the ACU (Aftertreatment Control Unit). Do not turn off the battery cutoff switch while the lamp is lit. Urea water in the hose is being collected while the lamp is on. Turning the battery cutoff switch OFF while the lamp is on can damage the system or the engine.
- 31. CCV Heater Switch.** Pressing the switch and turning the key ON activates the CCV (Closed Crankcase Ventilation) heater. The switch LED lights up during operation. (It does not turn off automatically.) *Caution Refrain from leaving the key ON for long, as the high current consumption can cause the battery to run down. The CCV heater does not turn off automatically; turn off the CCV heater switch approximately 60 minutes after starting the engine.

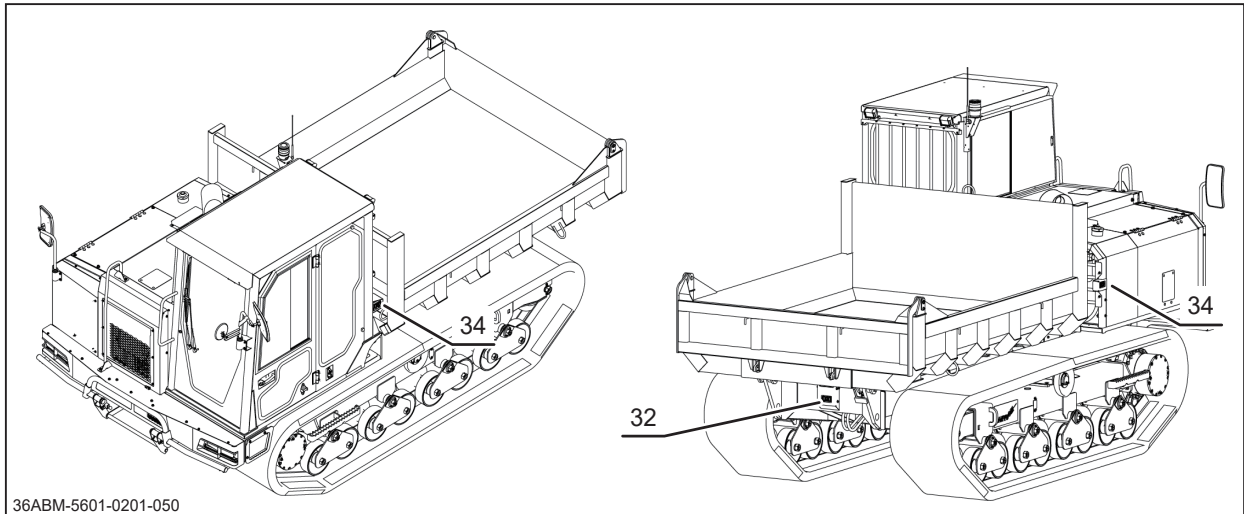

36ABM-5601-0201-050

32. Camera Captures the outside images.

LCD 1

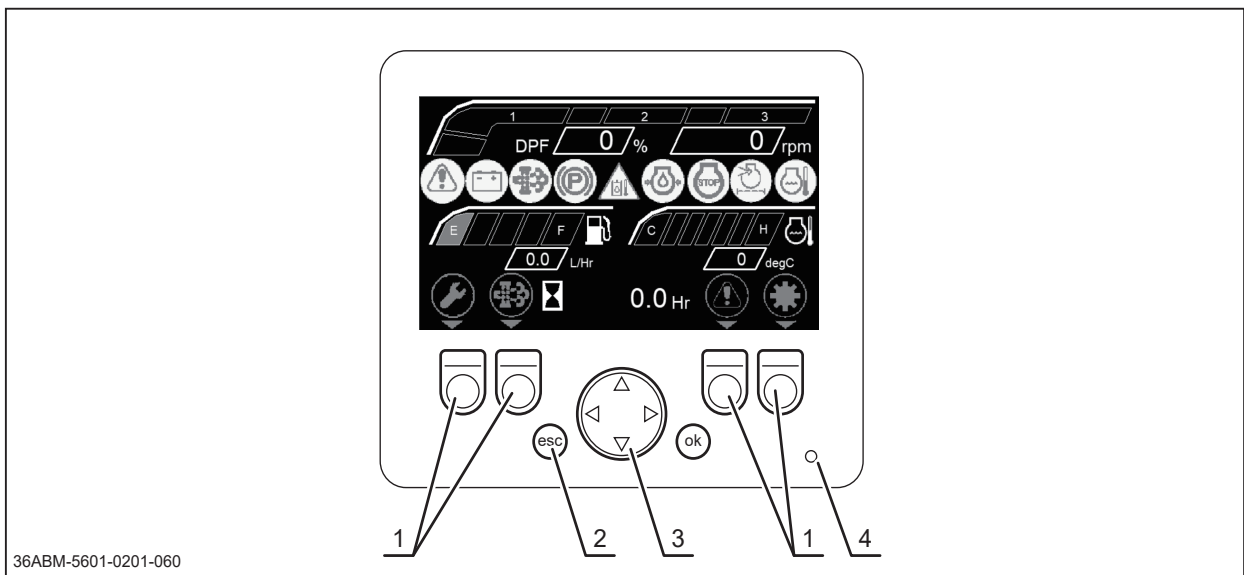

36ABM-5601-0201-060

1. **4-row Function Switch** . . . Functions differ for each screen page.
2. **ESC Switch** This is used to return to the previous page.
3. **Cursor Switch** This is used to change pages and move the cursor.
4. **LED** Lights up red in case of display failure.

For more details of the home screen, see Contents of Home Screen (page 53).

LCD 2

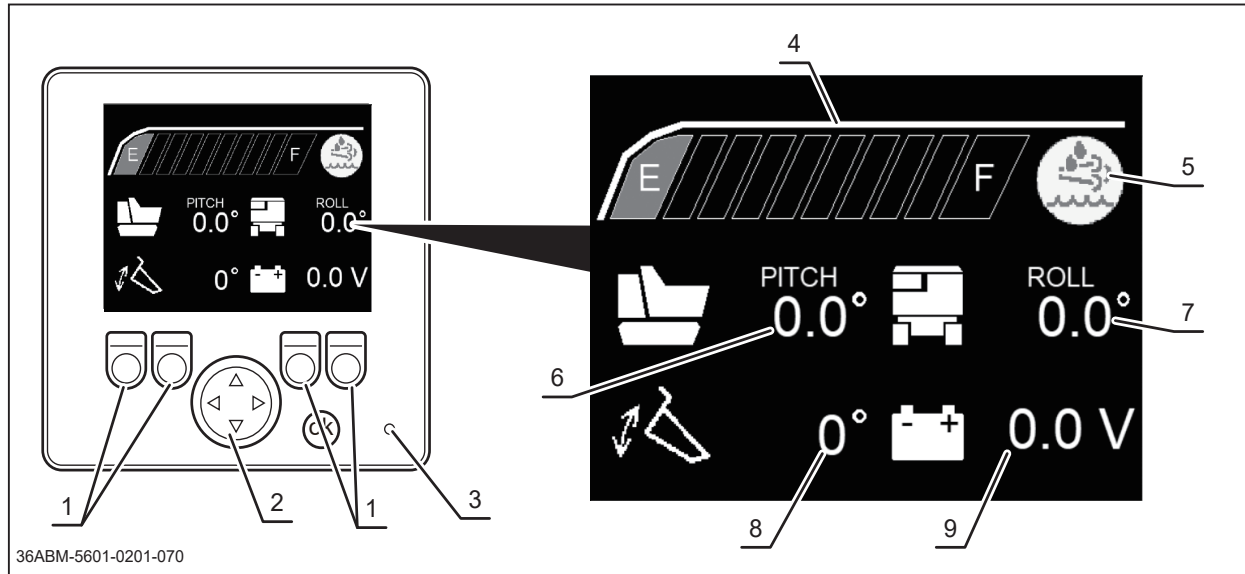

1. **4-row Function Switch** . . . Functions differ for each screen page.
2. **Cursor Switch** This is used to change pages and move the cursor.
3. **LED** Lights up red in case of display failure.
4. **Urea Gauge** Displays the amount of urea remaining in the tank.
F:Full / E: Empty
5. **Urea Level Warning** Lights up when the urea level is low. Flashes when the level drops further.
6. **Pitch Angle Indicator** Displays the angle of the vehicle body in the pitch (forward/backward) direction.
7. **Roll Angle Indicator** Displays the angle of the vehicle body in the roll (left/right) direction.
8. **Vessel Angle Indicator** Displays the angle of the vessel.
9. **Battery Voltage Meter** Displays the current battery voltage.

Product Specifications

NOTICE

- Understand the specifications of this machine thoroughly before use.

Model and Type		S500V		
		Straight Dump Model		
Machine Mass		kg (lbs)	6550 (14440)	
Max. Payload Capacity		kN (kg) [lbs]	49 (5000) [11023]	
Dimensions	Overall Length	mm (in)	4725 (186)	
	Overall Width	mm [in]	2250 (Rearview Mirror Retracted) [88.6]	
	Overall Height	mm [in]	2650 [104.3] (2550 [100.4] Rotating Lights Retracted)	
	Ground Contact Length	mm (in)	2320 (91.3)	
	Track Tread	mm (in)	1650 (65.0)	
	Minimum Ground Clearance	mm (in)	455 (17.9)	
	Vessel Floor Height	mm (in)	1130 (44.5)	
Vessel Dimensions	Vessel Inside Dimensions	Length	mm (in)	2600 (102.4)
		Width	mm (in)	2000 (78.7)
		Height	mm (in)	350 (13.8)
	Vessel Capacity	Struck	m ³ (cu ft)	1.81 (63.9)
		Heaped	m ³ (cu ft)	2.97 (104.9)
Engine	Model		Kubota V3800	
	Type		4-cycle, water-cooled, in-line 4-cylinder Diesel	
	Cylinder (Bore × Stroke)		mm (in)	100 x 120 (3.94 x 4.72)
	Total Displacement		cm ³ (cc) [cu in]	3769 (3769) [230.0]
	Rated Output		kW (PS)[HP] / rpm	95 (129.2) [127.4] /2400*1
	Max. Torque		N·m (kgf·m) [lbf·ft] / rpm	440.0 (44.87) [324.5] /1800
	Starting System			Electric starter
	Fuel Used			Diesel fuel
	Rate of Fuel Consumption		g/kW·h(g/PS·h) [oz / PS·h]	241 (177) [6.25]
	Fuel Tank Capacity		L (US gal)	125 (33)
	Lubricating Oil Capacity		L (US gal)	14.8 (3.9)
	Coolant Capacity		L [US gal]	13 [3.4] / Reservoir 1.1 L (1.2 US qt)
	AdBlue Capacity		L (US gal)	20 (5.29)
	Battery Type			170F51
Battery Capacity		V/AH(5HR)	12/108	

*1 Net output, without cooling fan.

Model and Type			S500V	
			Straight Dump Model	
Performance and Operating Range	Travel Speed	Gearshifting	HST (2-stage selection)	
		High Speed	km/h (mph)	0 to 14 (0 to 8.7)
		Low Speed	km/h (mph)	0 to 10 (0 to 6.2)
	Min. Turning Radius		m (ft)	approx. 3.1 (10.2)
Gradeability		degrees	25 (Empty)	
HST Oil Capacity		L (US gal)	90 (23.8)	
Power train	Main Gearshifting Method		HST (2-speed motor)	
	Steering System		2 pump - 2 motor system	
	Brake System		Negative Brake (Hydraulic)	
	Track		mm (in)	600 x 125 x 64 (23.6 x 4.9 x 2.5)
Dump system	Dump System		Hydraulic dump	
	Dump Type		Straight Dump	
	Hydraulic Pump	Type		Gear pump
		Maximum Speed	rpm	2400
		Capacity	cc/rev	22.8
	Relief Pressure		MPa(kgf/cm ²) [psi]	17.6 (180) [2552.6]
	Cylinder (Bore × Stroke)		mm [in]	(80 x 780) [3.1 x 30.7] x 2
	Performance	Max. Angle	degrees	60 *1
		Lifting Time	sec	Approx. 9.0
		Lowering Time	sec	Approx. 6.0
Hydraulic Fluid Capacity		L [US gal]	90 (Shared with HST System) [23.8]	
Air Conditioner	Refrigerant		HFC-R134A	
	Refrigerant Capacity		kg (lbs)	0.62 (1.37)
	GWP			1430
	Teq CO2		t (lbs)	0.887 (1955.5)
Operating Temperature		°C (°F)	between -20 (-4) *2 and +40 (104)	
Operating Elevation		m (yd)	below 1500 (1640) *3	

*1 The angle on a level ground. Maximum dump angle varies, depending on the angle of the ground and the machine.

*2 To start this machine under the following temperatures, you need an assistance from an external source via jumper cables. With standard battery: below -10 °C. With optional cold-weather battery: below -15 °C.

*3 Engine performance is reduced when used above 1500 m of elevation.

These specifications are subject to change without notice.

Contents of Tool Bag

EU Model

Check	No.	Content	Quantity	Note
<input type="checkbox"/>	1	Operator's Manual	1	This Manual
<input type="checkbox"/>	2	Operator's Manual for the Engine	1	
<input type="checkbox"/>	3	Around View Manual	1	
<input type="checkbox"/>	4	Around View Remote Control	1	
<input type="checkbox"/>	5	Audio Manual	1	
<input type="checkbox"/>	6	Battery Manual	1	
<input type="checkbox"/>	7	Wrench *1	1	For emergency dump valve
<input type="checkbox"/>	8	Cabin Key	1	
<input type="checkbox"/>	9	UKCA Declaration of Conformity	1	
<input type="checkbox"/>	10	CE Declaration of Conformity	1	

*1 See page48 **Emergency Dump Valve**.

US Model

Check	No.	Content	Quantity	Note
<input type="checkbox"/>	1	Operator's Manual	1	This Manual
<input type="checkbox"/>	2	Operator's Manual for the Engine	1	
<input type="checkbox"/>	3	Around View Manual	1	
<input type="checkbox"/>	4	Around View Remote Control	1	
<input type="checkbox"/>	5	Battery Manual	1	
<input type="checkbox"/>	6	Wrench *2	1	For emergency dump valve
<input type="checkbox"/>	7	Cabin Key	1	

*2 See page48 **Emergency Dump Valve**.

Preparation

Pre-start up Inspection

Always perform an inspection before use.

Refer to **Maintenance Schedule** (page 68) for the inspection schedule and procedure.

Checking and Filling Fuel

⚠ WARNING

- Keep fire and spark away when handling fuel.
- Always stop the engine before refueling.
- Do not overfill fuel above the limit (the bottom of the fuel filler filter) so that fuel will not overflow. In case fuel is spilt, wipe out immediately.

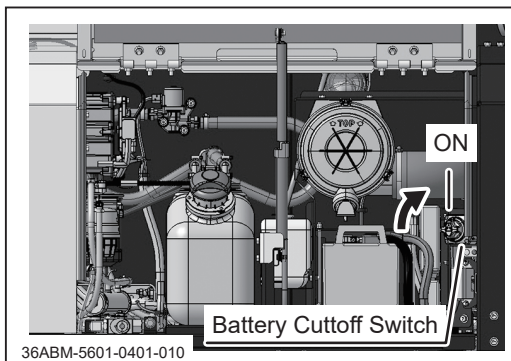

Checking Fuel

1. Make sure the battery cutoff switch is in the [| (ON)] position.

NOTE

- The battery cutoff switch is under the side service door. (See Side Service Door, page 78.)

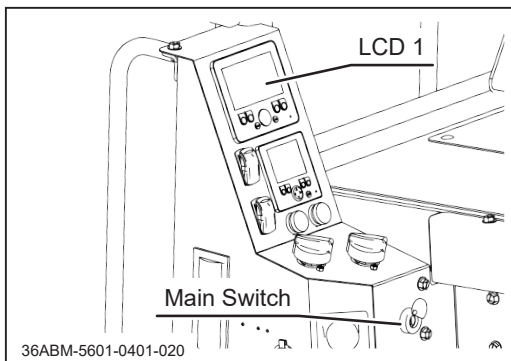

2. Insert the key into the main switch, turn it to the [| (ON)] position, and wait for a few seconds.
3. Check the fuel gauge. If the fuel level is low, fill fuel.
4. Turn the main switch to [○ (OFF)] position and remove the key.

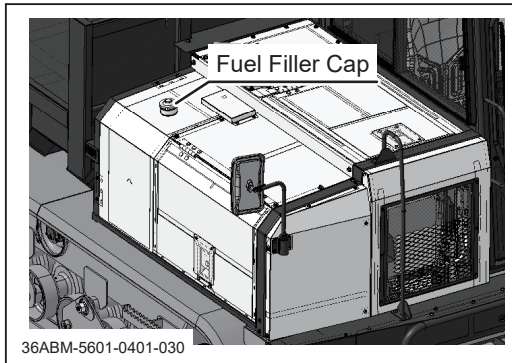

Filling Fuel

1. Open the filler cap.
2. Insert key in the main switch and turn it to the [○ (ON)] position.
3. Fill fuel. Check the fuel gauge when filling.
4. Turn the main switch to the [| (OFF)] position and remove the key.
5. Put the fuel filler cap back and tighten it securely.

NOTE

- Fuel : Diesel Fuel.
- Fuel Tank Capacity : 125 L

Adjusting Seat

⚠ WARNING

- When adjusting the seat, make certain the seat is securely locked.

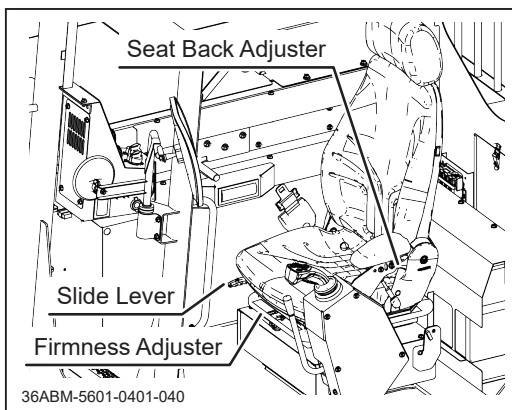

Adjusting seat

1. Pull the seat slide lever to slide the seat to a desired position.
2. Pull the seat back adjust lever to adjust the seat back to the desired position.
3. Turn the firmness adjuster dial to adjust the firmness of the seat to suit the operator's weight and preference. Turn the firmness adjuster dial fully to undo it.

Adjusting Mirrors

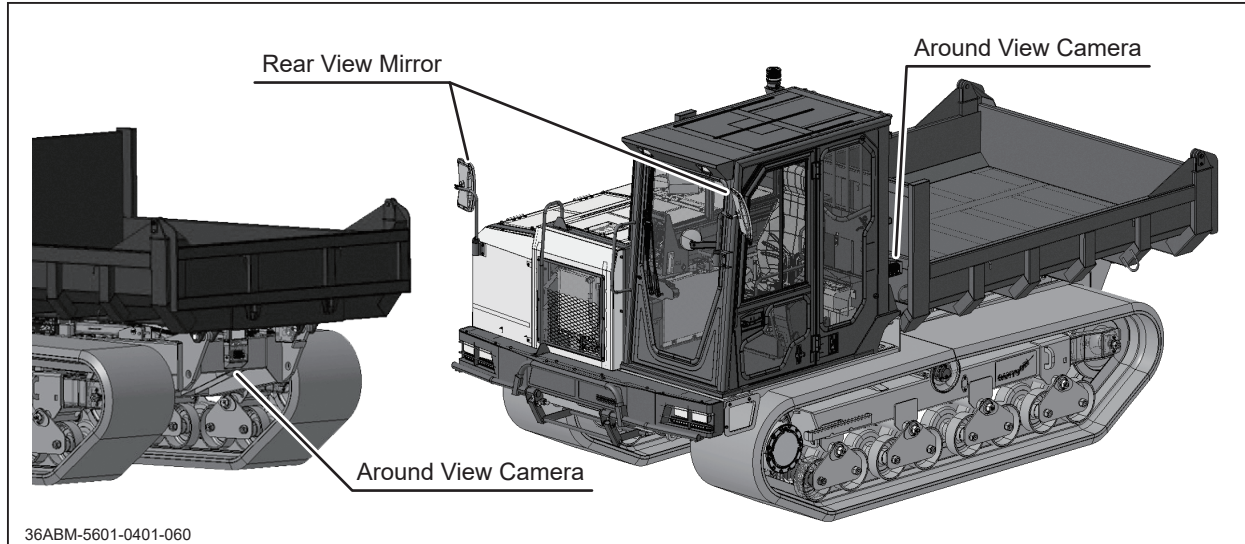

1. Adjust the mirrors so that you can see the front, rear, left, and right of the machine.
2. Check that the mirrors and the Around View cameras are clean and not damaged.

Using Seat Belt

⚠ WARNING

- On the machine equipped with the ROPS, Always wear the seat belt.

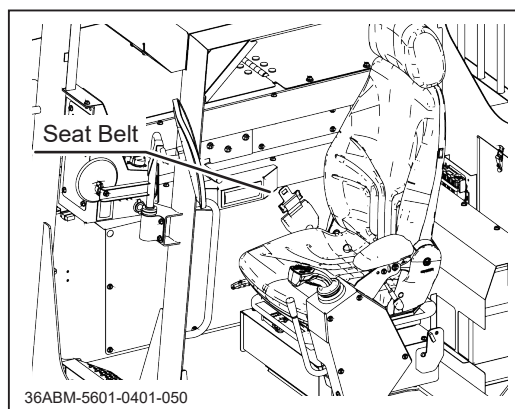

1. Buckle up seat belt. Adjust seat belt so that it fits snugly over the pelvis.

Driving

Starting

⚠ WARNING

- Always start and run the engine in a well ventilated place.
- Always make certain of the safety of your surroundings when starting the engine.
- Always stay on the seat when starting the engine. Never attempt to start the engine away from the machine. Run over accident can result.
- An engine that has been running is very hot. Avoid touching the engine and its ancillaries, or severe burns can result.
- Do not open the engine hood while the engine is running.

NOTICE

- Do not turn the starter when the engine is running. Starter motor and/or the engine can be damaged.
- Do not turn the starter for more than 15 seconds. If the engine does not start, turn it back to the [ OFF] position and wait for 30 seconds or more before attempting to start again.
- Do not use this machine in the temperatures above 40 °C (104 °F) or below -15°C (5 °F). This machine cannot perform adequately in these temperature ranges. Using this machine under such conditions can result in an accident or cause damage to the machine.
- In the winter or cold climate, warm up the engine thoroughly before driving the machine. A cold engine delivers poor performance, which can result in an accident. It also causes premature wear.

NOTICE

- Do not use this product in dusty places such as desert. Dust can clog the air cleaner or enter the engine, which can result in loss of performance and an accident. It also causes premature wear.
- Do not use this machine in the altitude above 1500m in its original configuration. This machine cannot perform adequately above that altitude. Using this machine under such conditions can result in an accident or cause damage to the machine. If you need to use this machine above that altitude, contact your CANYCOM representative.

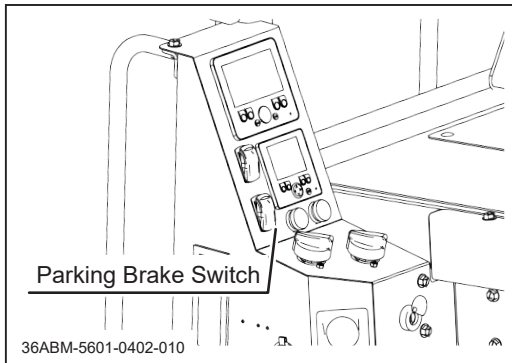

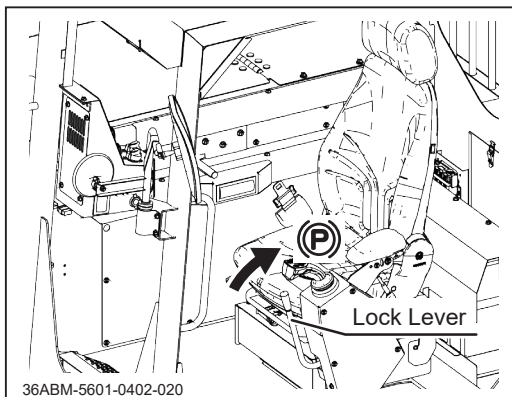

1. Make sure the parking brake switch [(P) (PARKING)] is pressed down.

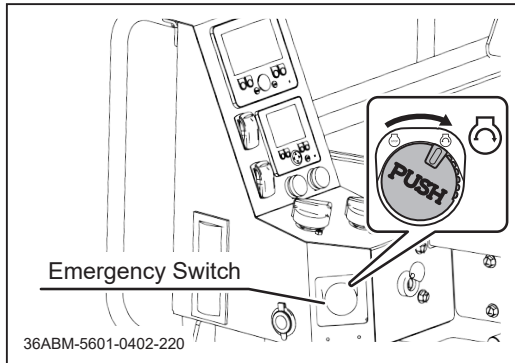

2. Make sure the lock lever is in the [(P) (PARKING)] position.



3. Make sure the emergency switch is in the [ (RUN)] position. If not, turn this switch to the right to the [ (RUN)] position.

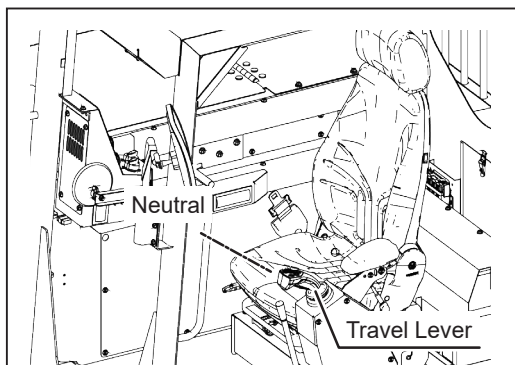

4. Make sure the travel lever is in the neutral position.

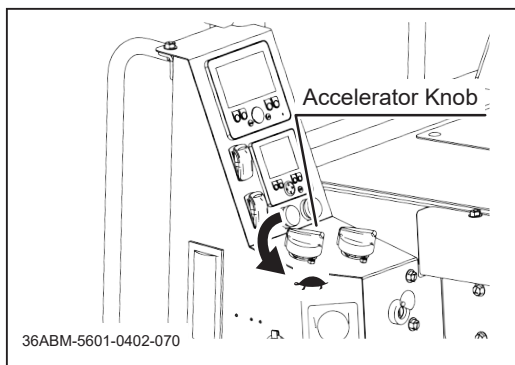

5. Move the accelerator knob to [ (SLOW)] position.

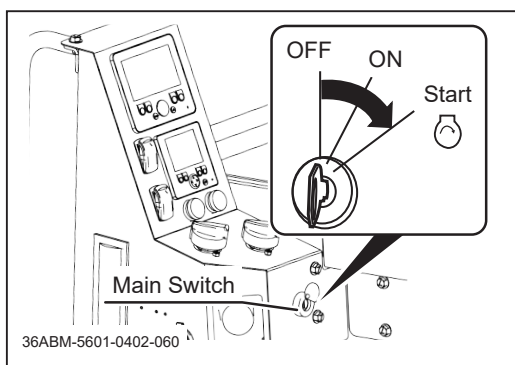

6. Turn the main switch to the [ (START)] position to start the engine. Once the engine starts, release the key immediately; switch will automatically return to the [| (ON)] position.

NOTE

- When the key switch is turned ON, preheating will start automatically. Stand by for preheating:
 5 seconds at 0°C to 10°C
 10 seconds at -10°C to 0°C
- To avoid draining the battery when the engine is cold and does not start, repeat OFF→ON (preheating for 5 second) sequence.
- If the battery voltage is below 10.5V, charge the battery before starting.

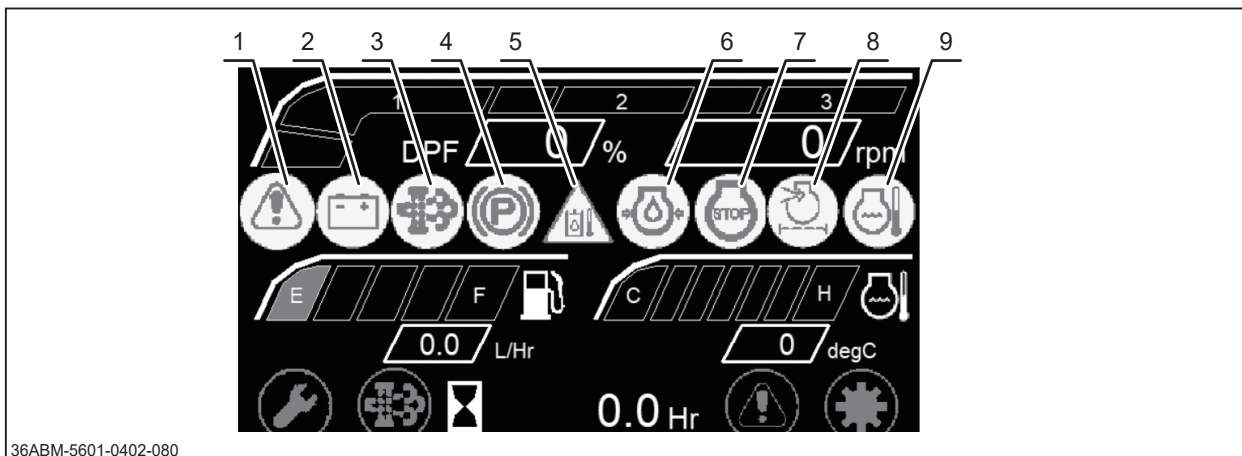

36ABM-5601-0402-080

7. Make certain that none of the warning lights are not lit. If any of them is lit, stop the engine immediately and refer to the **Troubleshooting** (page 116) to take an appropriate measure.

NOTE

- List of warning lights:

[1] Error Indicator

[2] Charge Indicator

[3] DPF Cleaning Indicator

[4] Parking Indicator

[5] Hydraulic Fluid Temperature Warning

[6] Oil Pressure Warning

[7] Emergency Engine Stop Indicator

[8] Clogged Air Cleaner Warning

[9] Coolant Temperature Warning

8. Allow the engine to warm up by running it for 3-5 minutes without any load. (It is not necessary when the engine is already warm.)

NOTE

- In cold weather, warm up the machine before use:
 - about 10 minutes above 0°C
 - 10 to 20 minutes between -10°C and 0°C
 - more than 30 minutes below -20°C
- Drive the machine gently in the first week (approximately 50 hours) of operation after purchase for breaking-in, keeping in mind the following:
 - Do not overspeed or overload the machine
 - Drive the machine after sufficient warming-up
 - Drive slowly on rough or inclined terrain

Driving

WARNING

- Do not allow bystanders to come near the machine when driving.
- Always stay seated in the operator's seat when driving the machine. Never operate the travel lever off of the machine. This can cause the machine to run over or crush the operator.
- Always wear the seat belt.
- Always make certain of the safety of your surroundings before driving; start slow.
- Always make certain of the safety of your surroundings before turning
- Do not make sudden starts, acceleration, change of speed, change of direction, or stop. Do not turn at speed. Avoid sudden maneuvers; this can cause the operator to fall, to be thrown, or the machine to tip over.
- Do not turn the key to the [○ (OFF)] position, press the parking brake switch (P), or move the lock lever to the [(P) (PARKING)] position while traveling. Machine can lose stability and cause the operator to fall, to be thrown, or the machine to tip over.

⚠ WARNING

- Always move the travel lever back to the neutral position before releasing. Letting it go from other operating positions can result in sudden deceleration and can cause the machine to tip over or the operator to fall or to be thrown.
- Do not drive the machine with its cabin door open.

NOTE

- If the parking brake switch (P) is [ON], the lock lever is in the [(P) (PARKING)] position, or the trigger switch is not pressed, the machine does not move when the travel lever is operated.
- If the parking brake switch (P) is [OFF] and the lock lever is in the [○ (DRIVE)] position, the machine moves when the travel lever is operated with the trigger switch pressed.

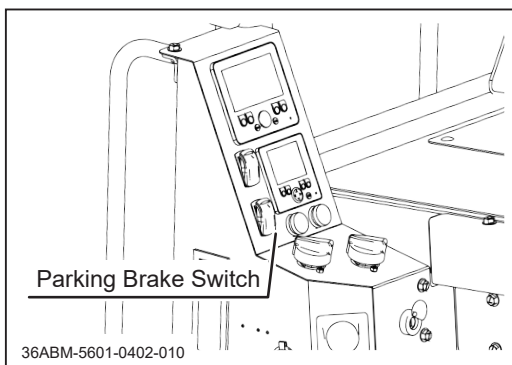

1. Make certain of the safety of your surroundings.
2. Turn parking brake switch to the [OFF] position.

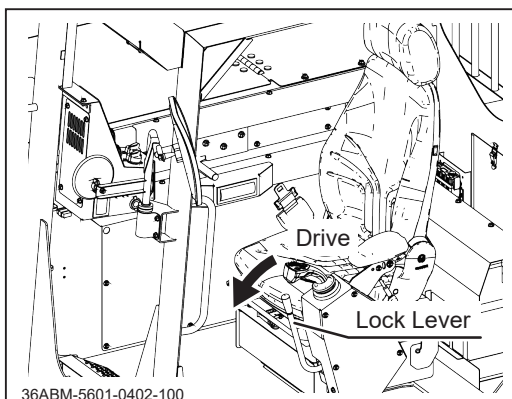

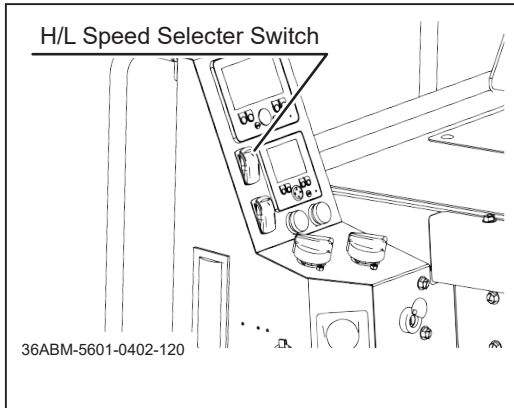

3. Move the lock lever to the [DRIVE] position.
4. With the joystick in the neutral position, press the trigger switch once. The horn sounds once to signal that the machine is ready to drive.

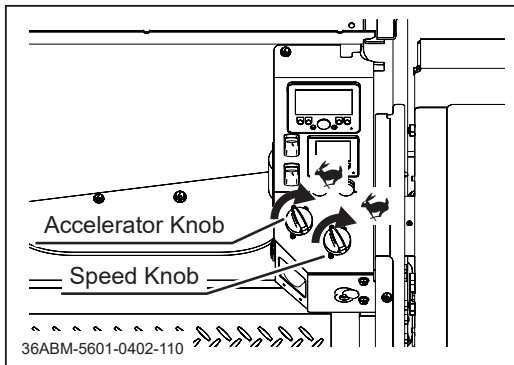

5. Push H/L speed selector switch to either the [L (LOW)] or the [H (HIGH)] position. For the speed range in either position, see Product Specifications (page 23).



6. Turn the accelerator knob toward the [ (FAST)] position to increase engine speed. Turn the speed knob toward the [ (FAST)] position.

NOTE

- Turn the speed knob approximately 30%.
- When the speed knob is at 0%, the machine does not run.

7. With the trigger switch pressed, tilt the travel lever (joystick) to drive the machine. The movement of the travel lever and that of the machine correspond as in the illustration. The speed can be adjusted as desired by the angle of the joystick; the maximum speed at the full tilt can be adjusted by the speed knob.
8. To make a spin turn, hold down the spin turn switch on the joystick and turn the joystick in the desired direction.

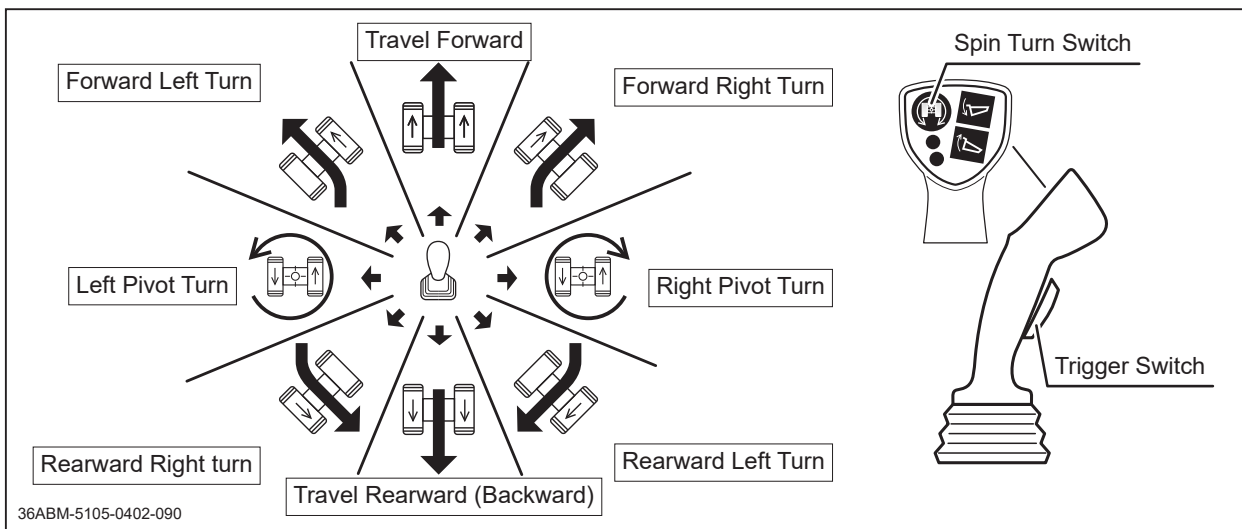

NOTE

- The buzzer sounds intermittently when backing up.
- When the spin turn switch is pressed, the buzzer will emit a continuous (beep...beep...beep...) sound.

Stopping**⚠ WARNING**

- Do not make a sudden stop. The machine can skid or tip over.
- Do not release the travel lever suddenly when stopping. The machine can stop suddenly and skid or tip over. Operate it gradually so that the machine slows gradually.
- Always park on a firm, level place. Never park on a potentially dangerous place.

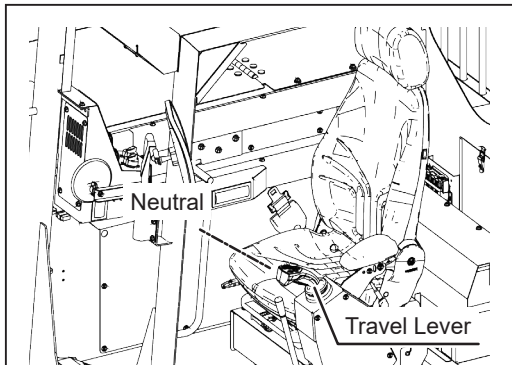

1. Move the travel lever gradually to the neutral position to stop the machine.

NOTE

- **Emergency Engine Stop:** This machine has emergency engine stop function. When the machine is tilted over 60 degrees for more than 3 seconds, the engine is stopped.
- When the engine is stopped due to the emergency engine stop function, turn the main switch to the [OFF] position to avoid the battery from being drained.

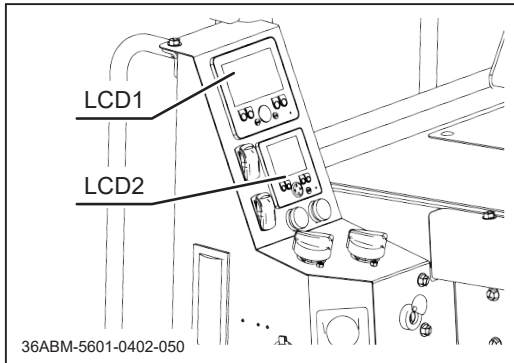

When the engine stops when an error is detected

When an error is detected in a sensor, actuator, etc., the engine will automatically stop and the cause of the error will be shown on the LCD1 display. If the engine stops due to such an error, take necessary measure before further operation.

If a error is detected, an error code will appear on the display. If an error code is displayed, contact your dealer.

NOTE

- If an error is detected by the engine or vehicle ECU, the error light on the display will light up.
- Do not use this machine when an error is detected. Take a necessary measure before using it. Using this machine with an error can result in a permanent damage to the machine or an accident.

Emergency Stop

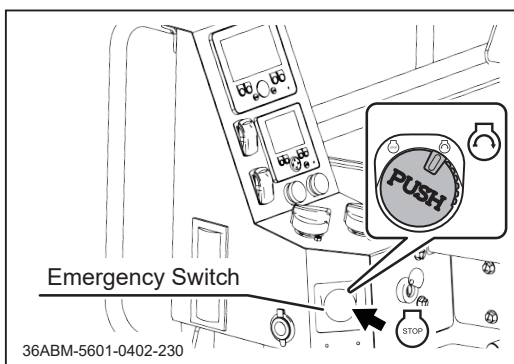

1. Pushing the emergency switch kills the engine.
2. Turn the emergency switch to the right to the [ (DRIVE)] position to reset.

NOTE

- When stopping the engine with the emergency switch, turn the main switch [OFF] as well. Leaving the main switch in [| (ON)] position drains the battery and cause it to discharge.

Parking

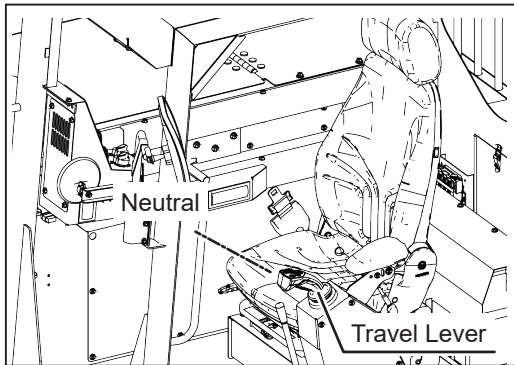

⚠ WARNING

- Always park on a firm, level place. Never park on a potentially dangerous place.
- Avoid parking on a slope. Never park on a slope with an incline of 15 degrees or steeper. If it is absolutely necessary to park the machine on a slope less than 15 degrees, make certain to apply parking brake firmly and block the tracks with chocks.

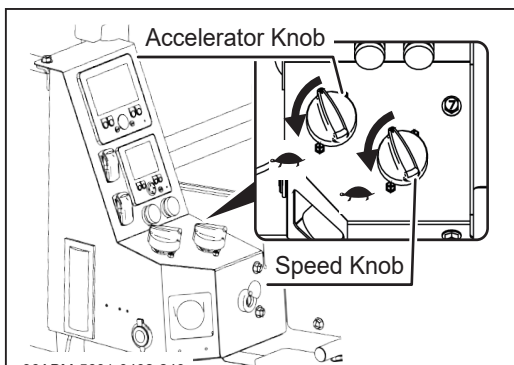

1. Move the travel lever gradually to the neutral position to stop the machine.



2. Move the accelerator knob toward the [ (SLOW)] position and the speed knob to the [ (SLOW)] position to decrease the engine speed.

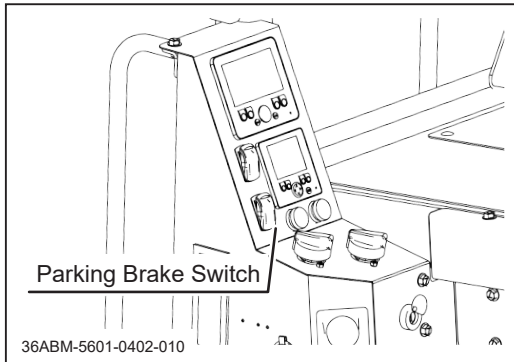

3. Press the parking brake switch (P) [ON] and move the lock lever to the [(P) (PARKING)] position.

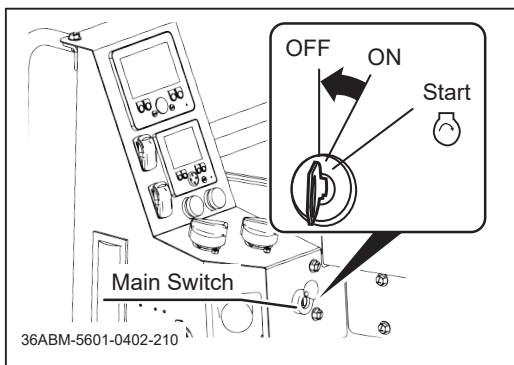
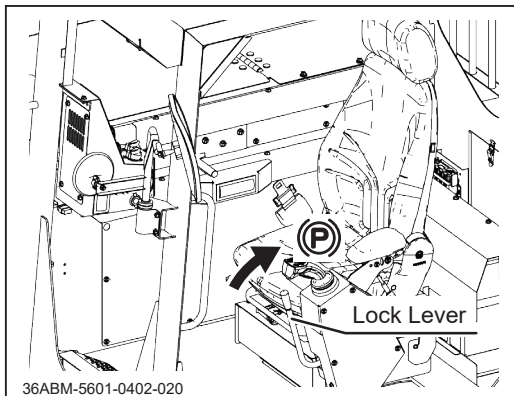

4. Turn the main switch to the [(O) (OFF)] position and remove the key from the main switch.

NOTE

- Leaving the main switch in [| (ON)] position drains the battery and cause it to discharge.

Working

⚠ WARNING

- Always make certain of the safety of your surroundings when dumping the bucket.
- Never operate the dump lever off of the machine. The bucket can hit or pinch the operator or bystanders.
- Avoid dumping the bucket on a slope. The machine can tip over.
- When servicing under the raised bucket, hold it with the safety prop.

NOTICE

- Always run the engine when dumping the bucket.
- When lowering the loaded bucket, slow the engine speed and lower the bucket gently.

Dumping

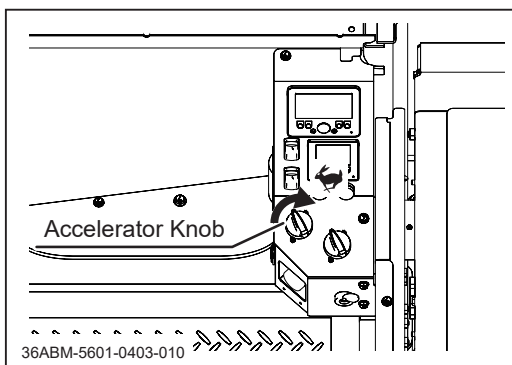

1. Start the engine and move the accelerator knob to the [ (FAST)] position to increase the engine speed.

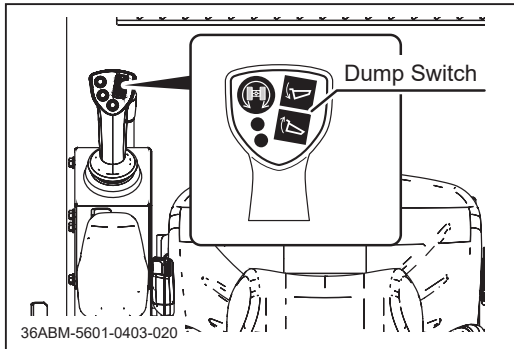

2. Press the dump up switch down gradually toward [↕ (up)] to raise the bucket.
4. When the bucket reaches its upper limit, it automatically stops; move the dump switch back to [● (neutral)].
5. Move the dump switch up gradually toward [↕ (down)] to lower the bucket.
6. When the bucket reaches its lower limit, a hissing noise is heard; move the dump switch back to [● (neutral)].

NOTE

- The bucket stops at 60 degrees from the horizontal.

Using Safety Prop

⚠ WARNING

- Place the safety props under the bucket when inspecting or working under the bucket.
- Use **BOTH** safety props; When used in pairs, they are designed to withstand the weight of an empty vessel.
- Unload the vessel when servicing under or around the vessel.

NOTICE

- Make certain to undo the safety prop before lowering the bucket.

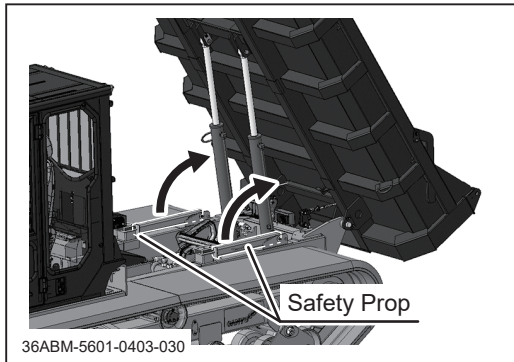

1. Raise the bucket.
2. Turn BOTH safety props upward against the bottom of the vessel.

Emergency Dump Valve

In case the engine or the hydraulic component malfunctions when the vessel (bed) is raised so the vessel cannot be lowered, you can use this valve to lower the vessel.

! DANGER

- Make sure there is no person or an object under or near the vessel (bed).

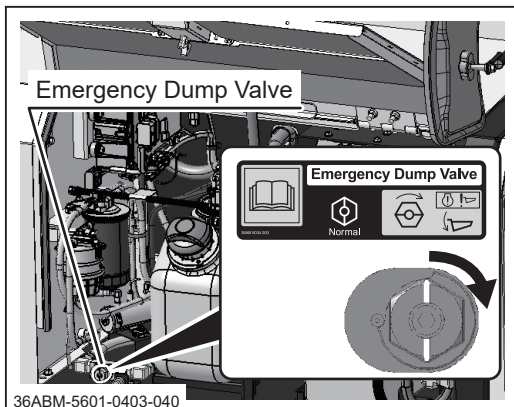

1. With the accessory wrench, turn the bolt on the valve 90 degrees counter-clockwise so that the white line in it becomes horizontal.
2. Once the vessel (bed) is fully lowered, turn this bolt 90 degrees clockwise so the white line becomes vertical.

Cabin

Air Conditioner

⚠ WARNING

- Do not insert fingers or other objects into the air inlet or outlet. The fan inside can cause injury.
- Always turn the keyswitch to [OFF] when cleaning, servicing, or inspecting the AC unit. The fan can rotate and cause injury.
- Do not expose your hands or feet to air from the AC vent for a long period of time. Do not touch the AC vent, surfaces, or refrigerant hose. Doing so can cause burns or frostbite.
- When the air conditioner is not in use for an extended period of time, close its louvers. Open louvers may allow dust and other debris to enter the air conditioner and cause it to malfunction.

NOTE

- When the engine is cold, heating does not work well. When the engine speed is low, cooling does not work well.

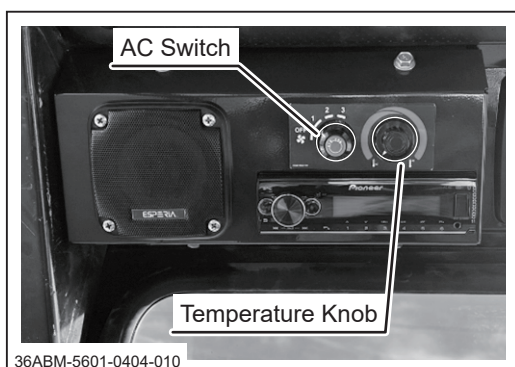

1. Push the AC switch to turn the air conditioner on. An LED is illuminated when the AC is on.
2. Turn the AC switch knob to adjust the fan speed.
3. Turn the temperature knob to adjust the air temperature; In the blue zone the air is cool and in the red zone air is hot.

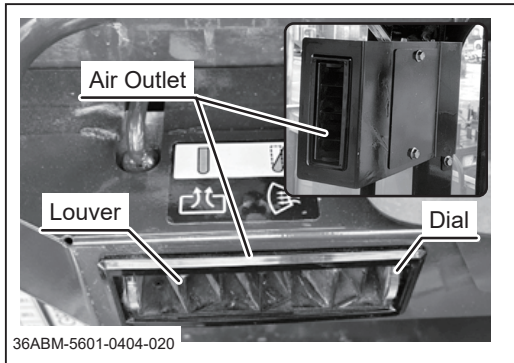

- Adjust the louver in the air outlet to adjust the direction of air. Turn the outlet wheel to open or close the outlet.

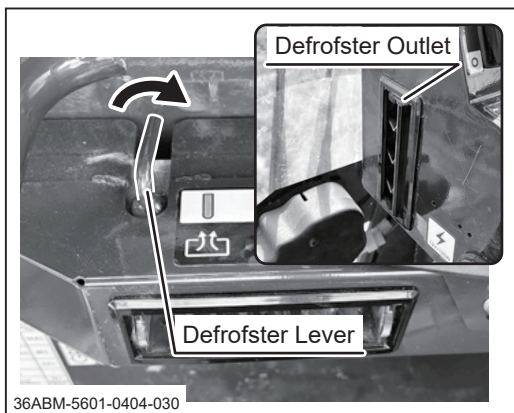

- Turn the defroster lever to defrost. Adjust the defroster outlet to adjust the area to be defrosted.

Emergency Equipments

⚠ DANGER

- In case of a small fire, use the fire attached extinguisher for initial firefighting; If fire is not manageable, immediately leave the machine.
- In case you are trapped inside the cabin, break the window with the attached hammer to escape. When escaping, watch out for the broken glass.

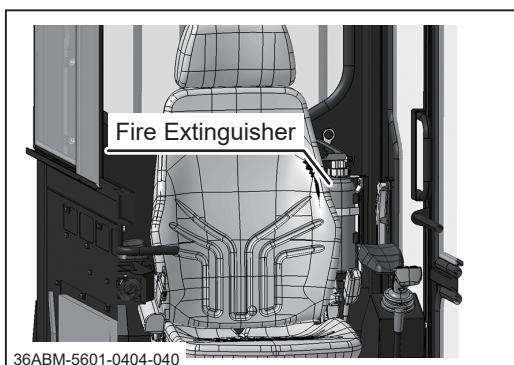

Fire Extinguisher

- Remove the fire extinguisher from its strap.
- Follow the instructions written in the label on the fire extinguisher to fight fire.

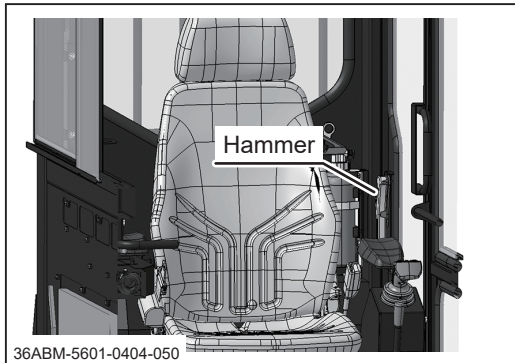

Emergency Hammer

1. Remove the hammer from the holder.
2. Break the glass on a window to escape.
3. Remove broken glass from the window frame so you will not be cut.
4. Escape from the cabin.

Warning Buzzer

This machine is equipped with a warning buzzer. It goes off under the following conditions:

Beeps	Condition	Note
Long beeps (Beeeeeep - Beeeeeep)	The machine is backing up.	-
Beeps in cycles of two. (beep beep - beep beep-)	Spin turn	Beeping continues while the spin turn switch is pressed.
Beeps in cycles of one. (beep -2s- beep -2s- beep -)	DPF Warning	Beeping continues regardless of operation. An error is shown in the display.

NOTE

- When driving at high speed and making a sharp turn, the warning buzzer can beep.
- The engine will automatically stop if the machine rolls over (when it is detected that the machine tilts over 60 degrees for more than 3 seconds).

Operating LCD - LCD1

Switches

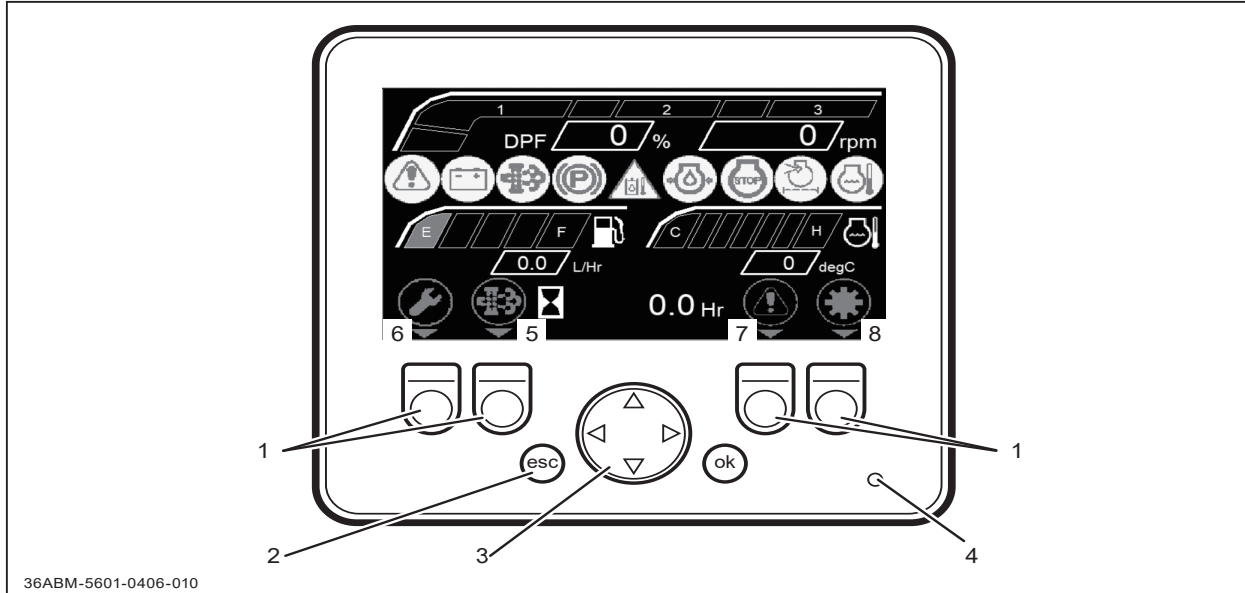

1. **Multifunction Switches** These switches serve different purposes, depending on the screen shown on the display. The following 5-8 are the functions in the home screen.
2. **ESC Button** Pressing this button calls up the previous screen.
3. **Cursor Switch**. This switch is used to flip through pages or to move the cursor.
4. **LED** Red LED turns on when the LCD malfunctions.
5. **DPF Switch** Pushing this begins DPF manual regeneration if the DPF Manual Regeneration Indicator is flashes and the condition for regeneration is met.
6. **Maintenance Switch** Pushing this brings up the (1) maintenance mode screen. If the maintenance message is present, this icon flashes.
7. **Error Switch** Pushing this brings up the (2)-1 current error screen.
8. **Screen Display Switch**. Pushing this brings up the (3) language / brightness screen.

Contents of Home Screen

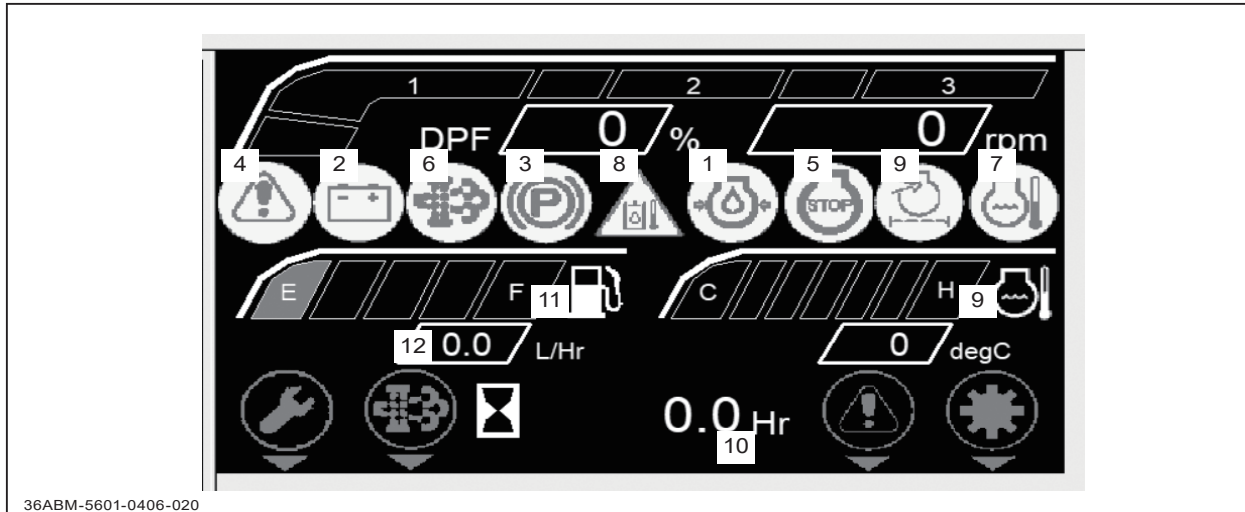

1. **Oil Pressure Warning** OFF while engine running: normal.
Lights up while engine running: low engine oil pressure.
Lights up while engine stopped: normal.

2. **Charge Warning** OFF while engine running: normal.
Lights up while engine running: charge error.
Lights up while engine stopped: normal.

3. **Parking Indicator** Lights up when the parking brake or the lock lever is engaged..

4. **Error Warning** Lights up when either the Engine ECU or Vehicle ECU is reporting an error. Push the error switch to check the description of the error.

5. **Engine Stop Warning** Lights up when the engine is stopped by the emergency switch or the tilt sensor.

6. **DPF Cleaning Indicator** Flashing when manual regeneration is required.
Lights up: manual regeneration is being performed.
OFF: Regeneration is not needed or has just been completed.

7. **Coolant Overheat** Lights up when the engine coolant gets 110 degrees
Warning Celsius or above.
8. **Hydraulic Fluid Overheat** . . Lights up when the hydraulic fluid (oil) gets 110 degrees
Warning Celsius or above.
9. **Aircleaner Clogging** Lights up when the air cleaner is clogged.
Warning
10. **Hour Meter** Displays the total number of hours that the machine has
been working in units of 0.1 hour.
11. **Fuel Gauge** Shows the remaining amount of fuel.
12. **Fuel Consumption Rate** . . . Displays a sampled rate of fuel consumption.

Maintenance Mode Screen

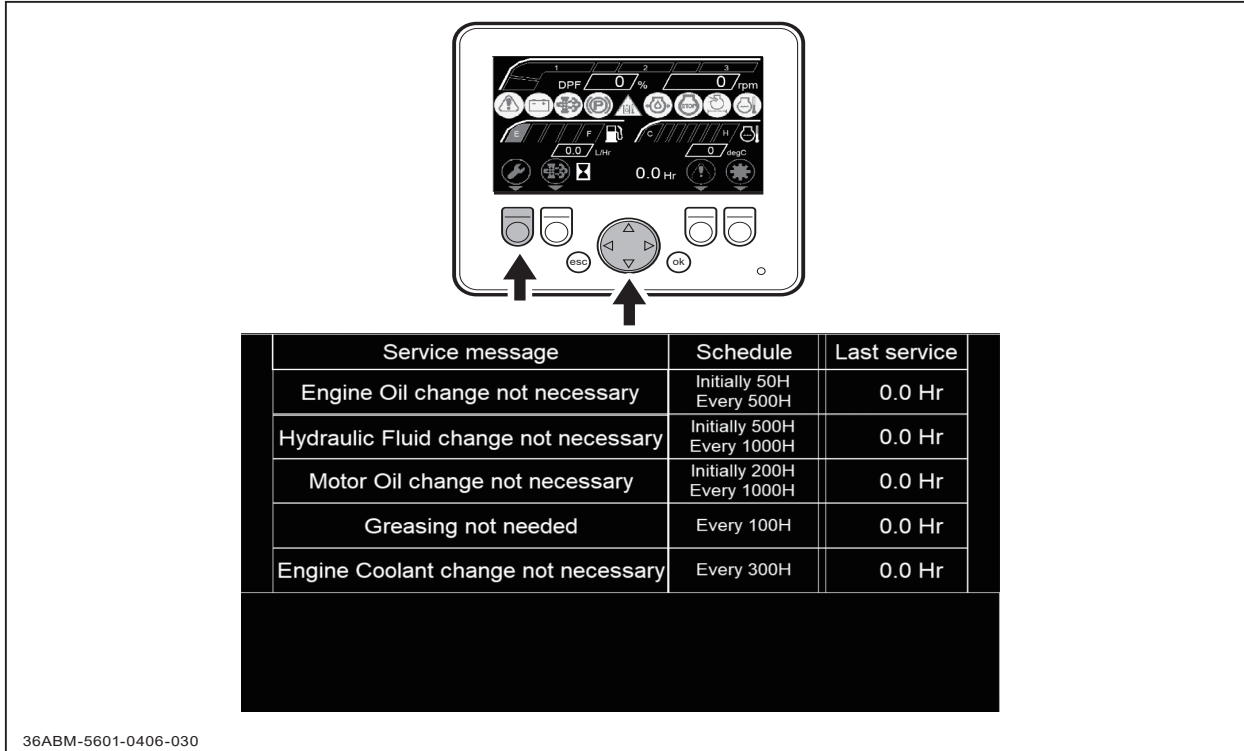

Service message	Schedule	Last service
Engine Oil change not necessary	Initially 50H Every 500H	0.0 Hr
Hydraulic Fluid change not necessary	Initially 500H Every 1000H	0.0 Hr
Motor Oil change not necessary	Initially 200H Every 1000H	0.0 Hr
Greasing not needed	Every 100H	0.0 Hr
Engine Coolant change not necessary	Every 300H	0.0 Hr

36ABM-5601-0406-030

How to Operate

Use the up/down cursor to select the message that is lit. Press the left-most function switch to turn off the message. The hour meter reading of the time when the switch is pressed is recorded as the Last Service time.

Message	Interval
Change Engine Oil	Initially 50 hr / Every 500 hr afterwards
Change Hydraulic Fluid	Initially: 500 hr / Every 1000 hr afterwards
Change Motor Oil	Initially: 200 hr / Every 1000 hr afterwards
Greasing Needed	Every 100 hr
Change Engine Coolant	Every 300 hr

Current Error Screen

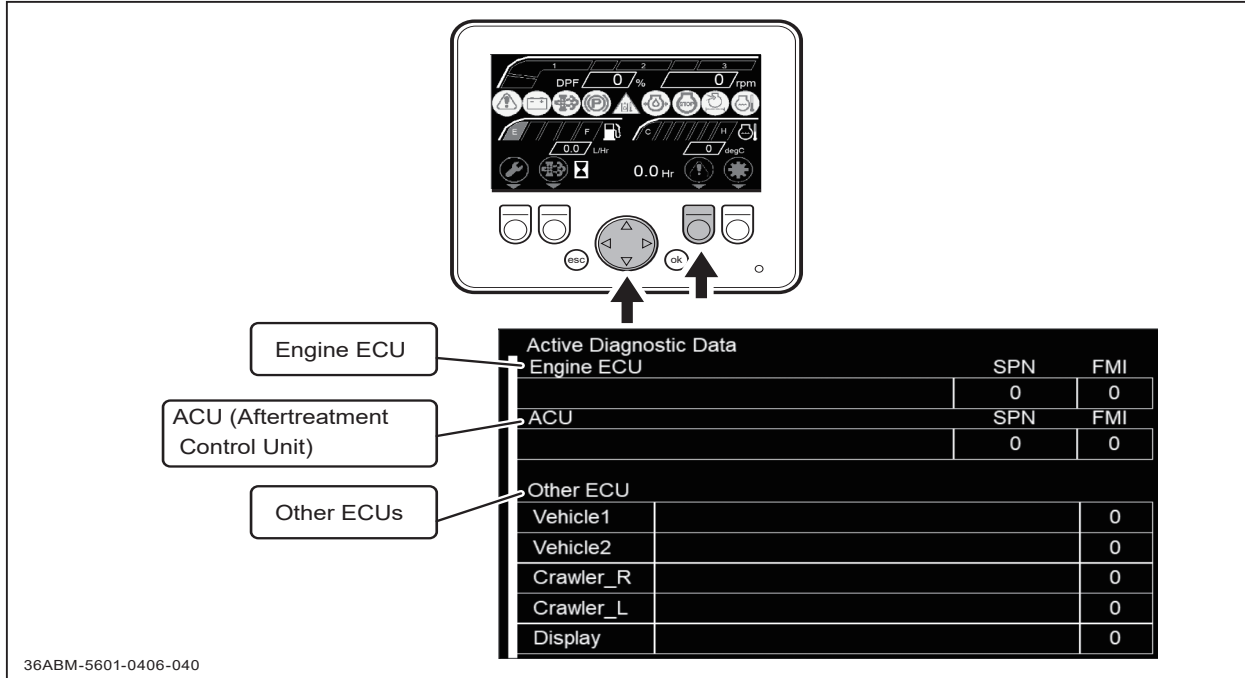

How to Operate

With the [Home Screen] showing, press button to bring up the [Current Error Screen].

ECU	Error Code	Description	Engine to Stop
Vehicle ECU 1	10	Rollover warning in pitch (front-rear) direction	√
	11	Rollover warning in roll (side) direction	√
	12	Hydraulic fluid overheat	√
	14	Air cleaner clogging	√
	56	Vessel control current (up) malfunction (+ side)	
	57	Vessel control current (up) malfunction (- side)	
	58	Vessel control current (down) malfunction (+ side)	
	59	Vessel control current (down) malfunction (- side)	

ECU	Error Code	Description	Engine to Stop
Vehicle ECU 2	41	Travel lever (joystick) neutral check malfunction	
Right-hand side Track ECU	5	Right-hand side track forward travel control current malfunction (+ side)	√
	6	Right-hand side track forward travel control current malfunction (- side)	√
	7	Right-hand side backward travel control current malfunction (+ side)	√
	8	Right-hand side backward travel control current malfunction (- side)	√
	9	Alternator charge malfunction	√
	21	Left track ECU CAN communication breakdown	
	38	Right track puls not detected	
	44	Throttle sensor disconnected	
	45	Throttle sensor short-circuit	
	46	Speed volume malfunction	
Left-hand side Track ECU	1	Left-hand side forward travel control current malfunction (+ side)	√
	2	Left-hand side forward travel control current malfunction (- side)	√
	3	Left-hand side backward travel control current malfunction (+ side)	√
	4	Left-hand side backward travel control current malfunction (- side)	√
	20	Right track ECU CAN communication breakdown	
	37	Left track puls not detected	
	50	Vessel angle sensor malfunction	
	60	Fuel sensor disconnected or its 5V circuit short-circuit	
Display	20	Right track ECU CAN communication breakdown	√
	21	Left track ECU CAN communication breakdown	√
	22	Vehicle ECU 1 CAN communication breakdown	
	23	Vehicle ECU 2 CAN communication breakdown	
	24	Engine ECU CAN communication breakdown	

Previous Error Log Screen

The diagram shows a control panel with a screen displaying 'Logged Diagnostic Data'. Below the screen are four buttons: two on the left, a central circular button with directional arrows, and one on the right labeled 'ok'. A callout points to the 'ok' button.

Logged Diagnostic Data			
Engine ECU, ACU	SPN	FMI	HOUR
none	0	0	0
none	0	0	0
none	0	0	0
none	0	0	0
none	0	0	0
Other ECU	ECU	CODE	HOUR
none	none	0	0
none	none	0	0
none	none	0	0
none	none	0	0
none	none	0	0

36ABM-5601-0406-050

How to Operate

With the [Current Error Screen] showing, press ► to bring up the [ECU Previous Error Log Screen].

Settings Screen

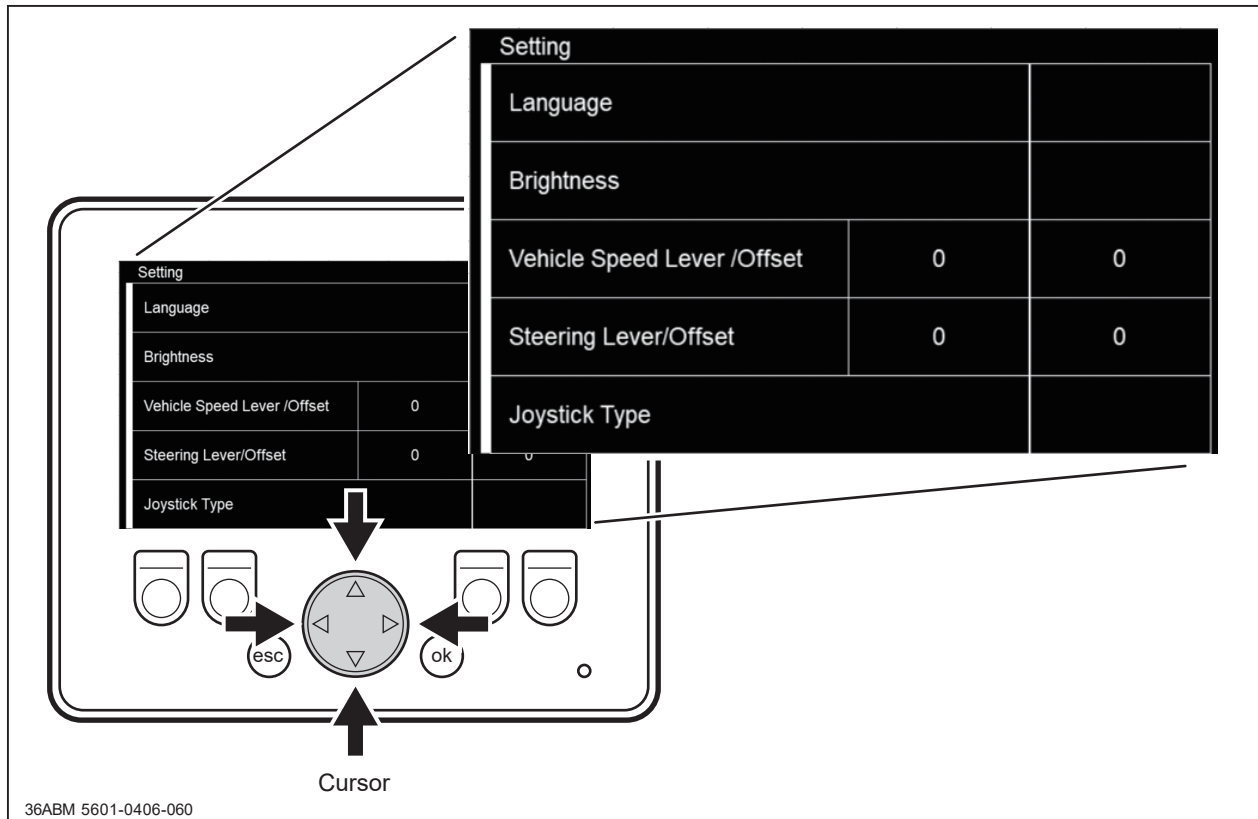

Select Language, Brightness, drive lever (joystick) offset, or vehicle speed sensor ON/OFF settings with the cursor [UP] and [DOWN], and change the settings with the cursor [LEFT] and [RIGHT].

- Language options: English, Japanese.
- Brightness options: Low, Mid, High.
- Travel Lever Offset

Vehicle Speed Offset: Offset value for the fore-aft direction of the joystick

Steering Offset: Offset value for the sideways movement of the joystick

NOTE

About the Offset value: If the output value deviates from [512] when the joystick is set to neutral, it may cause errors or the vehicle malfunctions. The Offset value can be set to be close to [512] with the cursor switch; Press ◀ to change the offset value by -1 and press ▶ to change it by +1. A change of 1 in the offset value changes the output value by 4.

- Vehicle Speed Sensor Use: ON (to use) or OFF (not to use)

ON: Default setting. Rotational sensor inside the drive motor is used to control the track speed.

OFF: In this setting, the rotational sensor inside the drive motor is not used, and the track speed is solely controlled by the angle of the swash plate inside the drive pump. Therefore, the machine may not travel straight, depending on the characteristics of the pump or the motor.

NOTE

Use the OFF mode only when the rotational sensor malfunctions. In this mode, the brake is applied immediately when the joystick is brought to neutral, and that can damage the brake disk.

Data Display Screen

This screen is to check the status of the engine ECU and controller. Use it to check detailed vehicle information.

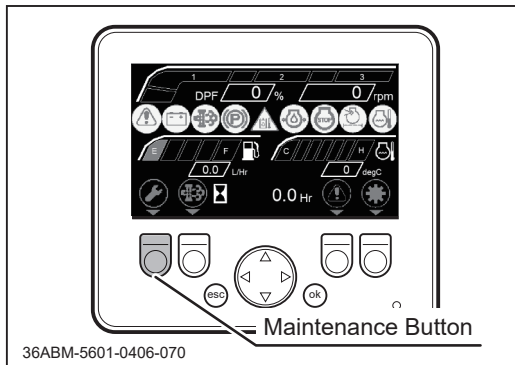

1. Press the maintenance button to display the maintenance screen.

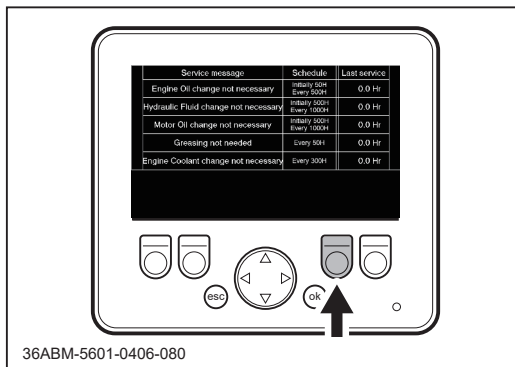

2. In the maintenance screen, press the second switch from the right for for 2 seconds to bring up the data display screen.

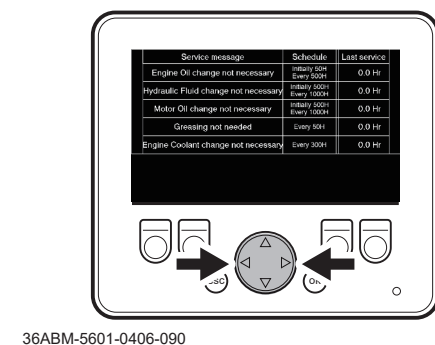

3. In this screen, detailed information on the vehicle is displayed; use the left and right cursor switches to flip between the ECUs to be displayed.

NOTE

- P1: Engine ECU
- P2: ACU (Aftertreatment Control Unit)
- P3-P4: Right-hand Side Track ECU
- P5: Left-hand side Track ECU
- P6: Vehicle ECU 1
- P7: Vehicle ECU 2

Engine Data

No.	Display	Description	Unit / Note
1	Throttle Position	Throttle opening level	%
2	Battery Potential	Battery voltage	V
3	Total Fuel used	Cumulative fuel consumption	L
4	Engine Speed	Engine Speed	rpm
5	Percent of Load	Engine load	%
6	Engine Oil Pressure	Engine oil pressure	kPa
7	DPF1 Soot Load Percent	Level of soot in DPF	% Regeneration starts automatically over 100%
8	DPF Status	DPF status	Not needed: Regen not needed Lowest Level: Soot level low Moderate Level: Soot level medium Highest Level: Soot level high
9	Regen Levels	Regeneration level	0: Regen not needed 1: Automatic Regen 2: Regen request at parking 3: Regen at parking 4: Regen with service tool 5: DPF cleaning
10	Regen Status	Regeneration state	Not active: Not regenerating Active: Regenerating Regen needed: Regen requested

ACU (Aftertreatment Control Unit) Data

No.	Display	Description	Unit / Note
1	Aftertreatment Intake Percent O2	Oxygen level at the aftertreatment intake	%
2	Aftertreatment Outlet Percent O2	Oxygen level at the aftertreatment outlet	%
3	Aftertreatment Outlet Gas Sensor Heater Control	State of heater for aftertreatment outlet gas sensor	Automatic: Automatic Preheat 1: Preheat 1 Preheat 2: Preheat 2 Heat off : Heat off
4	Aftertreatment DEF Concentration	Level of DEF in aftertreatment	%
5	Aftertreatment DEF Property	Property of DEF in aftertreatment	Conc. too high: Mixture is too concentrated. Conc. too low: Mixture is too dilute. Fluid is diesel: Diesel fuel is in the SCR tank. Proper mixture: Mixture is proper. Fluid unknown: F Error: Error
6	Aftertreatment SCR Operator Inducement Severity	Aftertreatment SCR Operator Inducement Severity	: Nothing displayed No active: Not active Initial warning: Initial warning Low level active: low level active Waiting: Waiting Severe Active: Severe active Restored: Restored
7	Aftertreatment 1 SCR Intake Temperature	Intake temperature at aftertreatment 1 SCR intake	degrees, celsius
8	DEF Level	DEF level	%
9	DEF Lamp Status	Status of DEF lamp	OFF: Unlit ON: Lit BLINK: Blinking

Right-hand Side Track ECU Data

No.	Display	Description	Unit / Note
1	OUTPUT0 - Blinker	Blinker output	1: ON 0:OFF
2	OUTPUT1 - Brake Release Valve	Brake release valve	1: ON 0:OFF
3	INPUT0 - Eco Mode Switch	Eco-mode switch	1: ON 0:OFF
4	INPUT1 - Parking Brake Switch	Parking brake switch	1: ON 0:OFF
5	INPUT2 - Charge Switch	Charge switch	1: ON 0:OFF
6	Crawler_R Duty/Target_I/Act_I	Right-hand side track duty / target current / actual current	Duty: % Target/Actual Current: A
7	Crawler_R Target Speed/Act Speed	Right-hand side track target speed / actual speed	Target/Actual speed: km/h
8	Engine Stop Request	Engine stop request	1: ON 0:OFF
9	Charge Indicator Lamp Request	Charge indicator lamp request	1: ON 0:OFF
10	Travel Stop/Travel Permit	Travel stop / Travel allowed	1: ON 0:OFF
11	Speed Limit	Speed limit volume position	%
12	Accel Pedal Position	Accel pedal position	%
13	Target Engine Speed	Target engine speed	rpm

Left-hand Side Track ECU Data

No.	Display	Description	Unit / Note
1	OUTPUT0 - Cooling Fan Valve	Cooling fan valve	1: ON 0:OFF
2	OUTPUT1 - Sub Transmission Valve	Subtransmission valve	1: ON 0:OFF
3	INPUT0 - Sub Transmission Switch	Subtransmission switch	1: ON 0:OFF
4	Crawler_L Duty/Target_I/Act_I	Right-hand side track duty / target current / actual current	Duty: % Target/Actual Current: A
5	Crawler_L Target Speed/Act Speed	Right-hand side track target speed / actual speed	Target/Actual speed: km/h
6	Engine Stop Request	Engine stop request	1: ON 0:OFF
7	Fuel Sensor 1	Fuel sensor	%
8	Bed Angle	Angle of the vessel	Degrees
9	Travel Stop/Travel Permit	Travel stop / Travel allowed	1: ON 0:OFF

Vehicle ECU 1 Data

No.	Display	Description	Unit / Note
1	OUTPUT0 - Back Buzzer	Backup buzzer output	1: ON 0:OFF
2	OUTPUT1 - Engine Stop Relay	Engine stop relay output	1: ON 0:OFF
3	INPUT2 - Air Cleaner Switch	Air cleaner switch	1: ON 0:OFF
4	INPUT3 - Hydraulic Oil TempSwitch	Hydraulic oil temperature switch	1: ON 0:OFF
5	Engine Stop Request	Engine stop request	1: ON 0:OFF
6	Air Cleaner Indicator Lamp Request	Air Cleaner Indicator Lamp Request	Target/actual speed : km/h
7	Hydraulic Oil Overheat Lamp Request	Hydraulic Oil Overheat Lamp Request	1: ON 0:OFF
8	Speed Lever / Steering Lever	Speed Lever / Steering Lever	Varies between 25 and 1000. Neutral at 512 (adjustment needed)

No.	Display	Description	Unit / Note
9	UpDown Duty/Target_I/ Act_I	Vessel dump valve duty/ target current/ actual current	Duty: % Target/Actual Current: A
10	Roll Angle/Pitch Angle	Roll angle/Pitch angle	Degrees

Operating LCD - LCD2

Home Screen

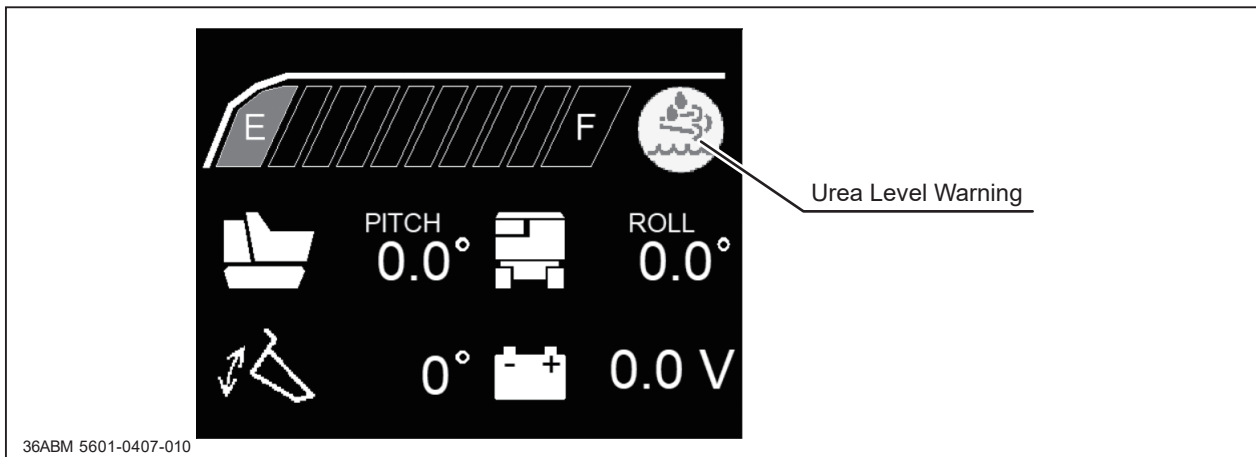

Urea level warning lights up when the urea level gets low. It flashes when the level nears empty.

Settings Screen

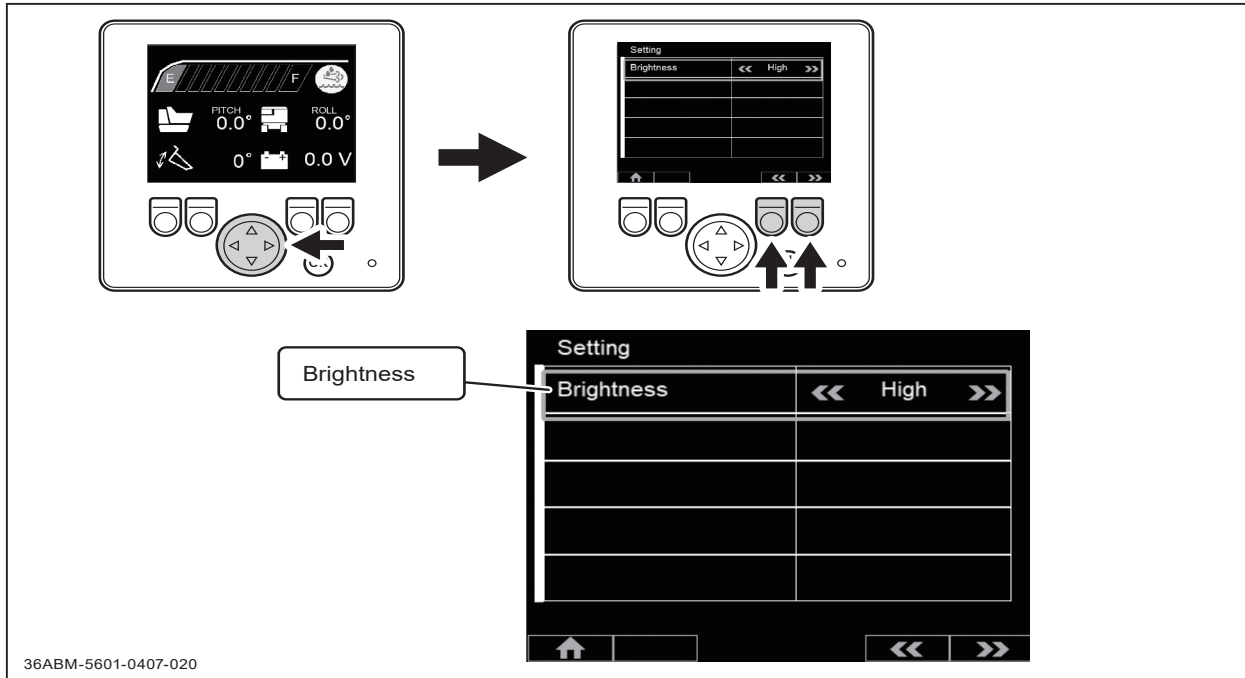

Press ► (right) in the cursor switch once in the home screen to bring up the setting screen. Change Brightness settings with the two left function switches directly below [<<] and {>>}.

- Brightness options: Low, Mid, High.

Maintenance Schedule

⚠ WARNING

- Follow the scheduled maintenance as described below. Failure to do so can result in mechanical or property damage, injury or death.

- Perform a pre-startup inspection (PSI) before each use, a monthly inspection once a month, and a yearly inspection once a year.
- Some maintenance procedures described below may require special knowledge or tools and instruments. Contact your CANYCOM representative to perform such procedures.

Item	Description	Schedule			Note	
		PSI	Mon	Year		
Engine General	Starting	Engine shall start easily without making any irregular noise.	√	√	√	
		Glow plugs work correctly.	√	√	√	
	Running	Engine speed shall be set properly at idle and at full without loading. Engine shall stay running smoothly.		√	√	Contact your CANYCOM representative for inspection.
		When accelerating engine, accelerator knob shall move smoothly, and engine shall accelerate smoothly without stopping or knocking.	√	√	√	
	Exhaust	Warm up engine thoroughly and observe exhaust sound and gas from idle to fast speed; exhaust sound shall be normal and smoke shall not be excessive.	√	√	√	
		There shall be no leak in exhaust system or muffler.		√	√	
	Air Cleaner	Air cleaner case shall not be deformed or cracked. Case lid and connecting air hose shall be firmly in place.		√	√	
		Cleaner element shall be in good shape without damage or excessive dust.		√	√	
	Fasteners	Bolts and nuts fastening cylinder head, intake, and exhaust manifolds shall be tightly fastened. * This may be skipped if there is no gas or water leaks found in these areas.			√	

Item		Description	Schedule			Note
			PSI	Mon	Year	
Engine	General	Valve Clearance Valve clearance shall be correct. *this may be skipped if there is no noise due to incorrect valve clearance, and engine runs normally.			√	Contact your CANYCOM representative for inspection.
		Compression Compression shall be correct. *this may be skipped if running and exhaust condition is normal at idle and under acceleration.			√	Contact your CANYCOM representative for inspection.
		Engine Mount Engine base shall be free of cracks or deformation. Mounting bolts and nuts shall not be loose or missing.	√	√	√	
	√		√	√		
	Lubrication System Oil shall be clean and at the correct level. No noticeable oil leaks shall be found in head cover, oil pan, or pipes.	√	√	√	Inspecting/Changing: page 81	
		√	√	√		
	Fuel System There shall not be anyleaks in fuel tank, hoses, or pipes. Fuel hoses shall be free of damage or deterioration. Fuel filter shall not be excessively dirty or clogged. There shall not be sediment or water in fuel tank. Injection pressure and injection condition from the nozzle shall be normal. * this may be skipped if running and exhaust condition is normal at idle and under acceleration.	√	√	√		
		√	√	√		
			√	√	Inspecting: page 92	
			√	√		
					√	Contact your CANYCOM representative for inspection.
	Cooling System Coolant shall be clean and at the correct level. There shall not be any leaks from radiator, engine, water pump, or hoses. Radiator fins shall be free of clogging. Radiator cap valve shall function properly. Fan belt shall be free of wear and damage, and shall be properly tensioned. Cooling fan, duct, and cover shall be free of cracks, damage, or deformation. Mounting bolts and nuts on cooling fan, duct, and covers shall not be loose or missing.	√	√	√		
		√	√	√		
		√	√	√		
				√		
				√		
				√		
				√		

Item		Description	Schedule			Note	
			PSI	Mon	Year		
Engine	Electrical System	Charge System			√	Contact your CANYCOM representative for inspection	
		Battery	Battery electrolyte level shall be correct.		√	√	Inspecting/filling: page 105
			Terminals shall be free of marked corrosion and are tightly secured.		√	√	
		Wiring	Connections shall not be loose and shall be securely connected.		√	√	
			Wiring shall be free of damages.		√	√	
Drivetrain	HST Pump	Drive the machine forward and backward, turn left and right in both directions; machine shall move normally and free of irregular noise or overheating.	√	√	√		
		Hydraulic fluid shall be filled to a proper level.		√	√	Inspecting/Changing: see page 99	
		Hydraulic fluid shall be clean and free of dirt or contamination.		√	√	Inspecting/Changing: see page 99	
		There shall be no fluid leaks in or around fluid tank.		√	√		
Undercarriage	Wheels Sprockets Idlers	Shall be free of cracks, deformation, or excessive wear.	√	√	√		
		There shall not be excessive play in axle. Irregular noise or overheating shall not be observed when travelling.	√	√	√		
		Mounting bolt or nut shall not be loose or missing.	√	√	√		
		There shall be no oil leak in or around axle.		√	√		
	Tracks	There shall not be marked cut, deterioration, or wear.	√	√	√		
		Track shall be properly tensioned, shall not be too loose or too tight.	√	√	√	Adjusting: page 96	
		Track core shall not be missing or damaged.	√	√	√		
		Tension bolt shall be free of deformation or corrosion.	√	√	√		
Brake System	Parking Brake	Parking brake shall work properly.	√	√	√		
		Parking brake shall be able to hold the machine on a 20-degree slope.		√	√		

Item	Description	Schedule			Note	
		PSI	Mon	Year		
Hydraulic System	Hydraulic Pump	There shall be no leak in or around hydraulic pump.		√	√	
		Fastening bolts and nuts shall not be loose or missing.		√	√	
		No irregular vibration, noise, or heat shall be observed when hydraulic pump is in operation.		√	√	
		Amount and pressure of discharge under load shall be within the standard range specified by the manufacturer. *this may be skipped if irregular vibration, noise, or heat described above is not observed.			√	
	Hydraulic Valve	There shall be no leak in or around hydraulic valve.		√	√	
	Plumbing	Plumbing shall be free of cracks, damage, twists, or deterioration.		√	√	
		There shall be no leaks in pipes, hoses, joints, or seals.		√	√	
		Plumbing shall be mounted properly, and fastening bolts and nuts shall not be loose or missing.		√	√	
		Breather shall not be clogged.		√	√	
	Hydraulic Cylinders	Shall work properly.		√	√	
		There shall be no leaks when extending and contracting cylinder.		√	√	
		Extend dump cylinder fully under load and hold. Stroke shall be within the range specified by manufacturer.			√	
		Cylinder tube and rod shall be free of dents, cracks, bends, or scratches.		√	√	
		Cylinder mounting pins shall be free of damage or excessive wear.		√	√	

Item	Description	Schedule			Note	
		PSI	Mon	Year		
Body, Chassis, Vessel	Chassis Frame	Shall be free of cracks, deformation, or corrosion.		√	√	
		Fastening bolts or nuts shall not be loose or missing.		√	√	
	Body Panels	Shall be free of cracks or deformation.		√	√	
		Doors shall open, close, and lock properly.		√	√	
		Fastening bolts or nuts shall not be loose or missing.		√	√	
	Vessel (Bucket)	Vessel shall be raised and lowered smoothly. Tailgate shall open and close smoothly.		√	√	
		Shall be free of cracks, deformation, or corrosion.		√	√	
		Fastening bolts or nuts shall not be loose or missing.		√	√	
	Safety Prop	Safety prop shall be free of any deformation.		√	√	
	Seat	Seat shall be adjusted properly and shall be locked securely.		√	√	
		Mounting fasteners shall be secure and not missing.	√	√	√	
	Labels	Warning labels and instruction plates shall be clean, legible, and free of damage.	√	√	√	
	Instruments Meters	Instruments shall work properly once engine starts.	√	√	√	
	ROPS, FOPS	ROPS/FOPS shall be free of deformation or corrosion.	√	√	√	
		Mounting fasteners shall be secure and not missing.	√	√	√	
	Seatbelt	Mount shall not be loose	√	√	√	
		Seatbelt shall be free of cuts or damages.	√	√	√	
	Emergency Switch	Engine shall stop immediately once emergency switch is activated.	√	√	√	
	Air Conditioner	Clean filter.	√	√	√	
		No dirt or foreign object shall be inside the AC unit. Clean, if any.	√	√	√	
Safety Devices	Head Light Work Light	Light shall work.	√	√	√	
		Light lens shall be free of cracks or chipping, and water shall not be in the light.		√	√	
	Horn	Horn shall work.	√	√	√	

Fluids and Lubricants

Item	Schedule	Grade	Cap.
Fuel	As needed.	Diesel Fuel No.2-D or No.2 D (Ultra Low Sulfur)	125L (33 US gal)
Diesel Exhaust Fluid (DEF)	As needed	AdBlue® (AUS 32 DEF)	20L (5.29 US gal)
Engine Oil	Fill Inspect daily. Fill as needed. Change Initially - After 50 hours of use. Every 500 hours afterwards.	Diesel Engine Oil API rating: CJ-4 or CK-4 JASO rating: DH-2 SAE rating: 10W-30	14.8L (3.9 US gal)
HST Fluid (also used as hydraulic fluid)	Change Initially - After 500 hours. Every 1000 hours afterwards.	High viscosity index hydraulic fluid, (EU model) PANOLIN HLP SYNTH 32 Viscosity 32, Bio-degradable (US model) ISO VG46 *2	90L (23.8 US gal)
Travel Motor Oil	Change Initially - After 200 hours. Every 1000 hours afterwards.	Gear Oil API rating: GL-4 SAE rating: 90	3.2L (3.4 US qt)
Grease Points	Every 100 hours.	Lithium all-round grease (NLGI No.2 or equivalent)	-
Engine Coolant	Check Everyday Fill as needed Change every 300 hours (every 6 months)	Long Life Coolant (LLC) and pure water Mixture (50% dilution)	13L (3.4 US gal) 1.1L*1 (1.2 US qt)*1
Battery Electrolyte	Inspect every 50 hours. Fill as needed.	Distilled Water	-

*1 Coolant Reservoir.

*2 When using in cold areas (below -15°C [5°F]) use wear resistant hydraulic fluid VG32.

Greasing Points

NOTICE

- Grease regularly. Insufficient greasing can result in seizure or rusting, affecting smooth operation of the machine.

NOTE

- When using a manual grease pump, pump 5-6 times. When the handle of the pump becomes heavy, stop pumping.
- When using a pneumatic grease pump, pump it for a few seconds.
- Grease to use: see page 73.

	Location	Lubrication points	Grade
1	Swing Pivot	8	Chassis Grease
2	Dump Cylinder Pin (Top)	2	
3	Dump Cylinder Pin (Bottom)	2	
4	Dump Pivot	2	
5	Tail Gate Pivot	2	
6	Lower Lock Roller	2	
7	Tail Gate Lock Pivot	2	

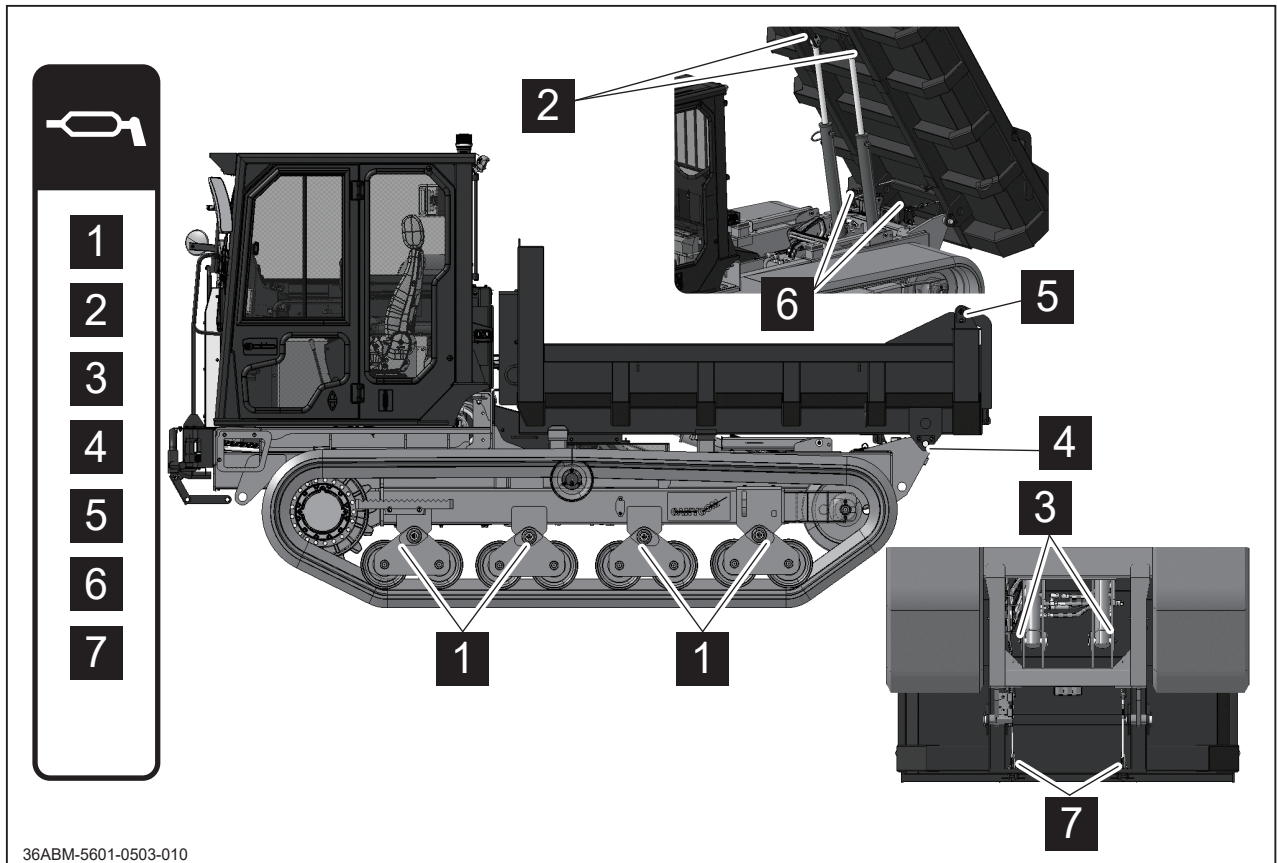



Consumables and Spares

NOTICE

- Use only CANYCOM genuine parts when replacement or repair is required. CANYCOM assumes no liability whatsoever if any problem occurs as a result of using any part that is not a genuine CANYCOM part.

NOTE

- Rubber products deteriorate over time. Replace them every 2 years.
- You can see our online parts manual at the URL or the QR code below:
<https://www.canycom.jp/eng/maintenance/parts/>
Go to the site and look up your model in the list. 
- Consumable parts are listed in a separate page for your convenience.
https://www.canycom.jp/maintenance/recomment/consumables_S500V.pdf
(This links to a PDF file. You need Adobe Reader or similar software to read it.) This file contains a list of items such as oil filter cartridge, air cleaner element, spark plug, drive belts and mower blades. Open this file to look up your model in the list. For other parts, refer to the parts catalog above. 
- In case you cannot see the above parts manual, contact your CANYCOM representative.
- Order replacement parts through your local CANYCOM representative.

Body Panels

DANGER

- Do not operate this machine with its safety covers removed or open. Serious injury or death could result.

WARNING

- Burn and run-on hazard. Do not touch the engine or muffler cover while the engine is running or soon after it has stopped.

CAUTION

- Cut or pinch hazard exists when removing or installing the body panels; beware of the sharp edges and pinch points.

Maintenance Ladder

CAUTION

- Make sure it is not damaged or deformed before using it.
- Make sure the non-slip sheet is not worn or detached. If it is, replace it.

NOTICE

- Retract the steps when driving. Failure to do so may result in damage if the product hits an obstacle, etc.

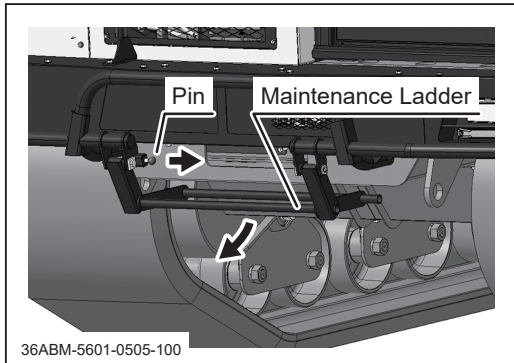

1. Hold the maintenance ladder and pull the pin.
2. Lower the ladder.

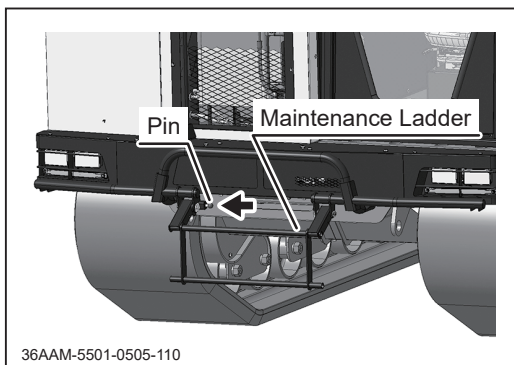

3. Once the ladder is fully lowered, insert the pin into the hole to secure the ladder in place.

NOTE

- Use the maintenance ladder when servicing under the engine hood.

Engine Hood

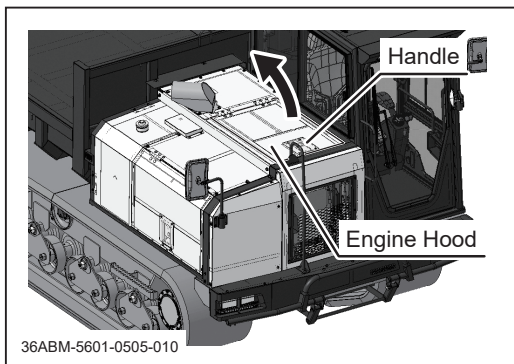

1. Pull the handle to open the engine hood. Raise the hood all the way up to a stop.

NOTE

- The hood is supported by a gas spring and stays open.

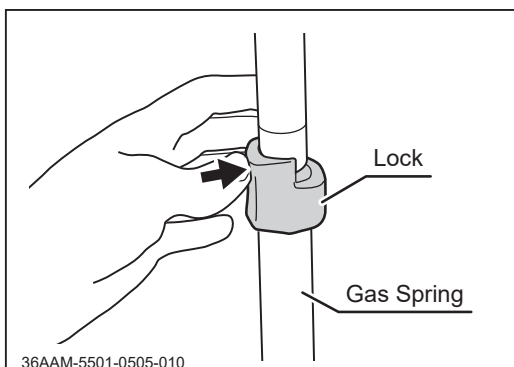

2. Push the gas spring lock and slowly push the hood to close.

NOTE

Side Service Door

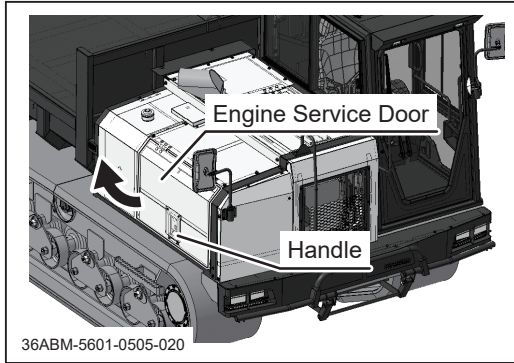

1. Pull the handle to open the side service door. Raise the hood all the way up to a stop.

NOTE

- The side service door is supported by a gas spring and stays open.

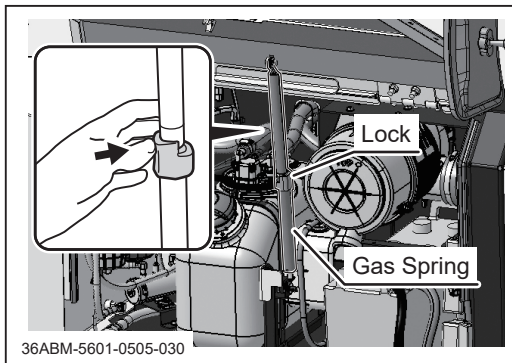

2. Push the gas spring lock and slowly push the engine service door to close.

NOTE

- The engine service door handle can be locked with the main key.

Side Covers

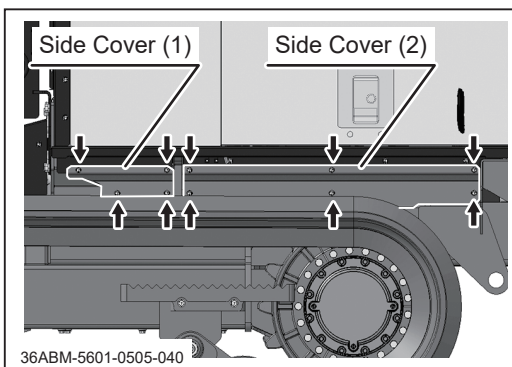

NOTE

- The side covers need to be removed when servicing the lower side of the engine. (e.g. oil filter, feed pump.)

1. Undo four (4) bolts to remove the side cover (1).
2. Undo six (6) bolts to remove the side cover (2).

Engine Room Rear Grill

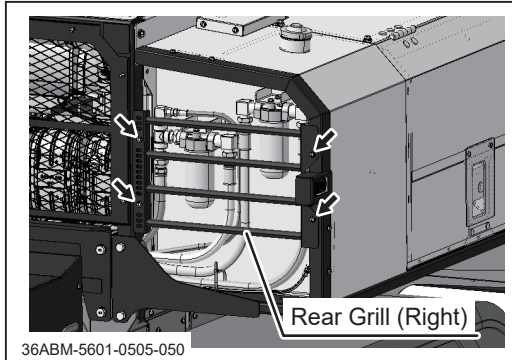

1. Remove four (4) bolts to remove the engine room rear grill (right).

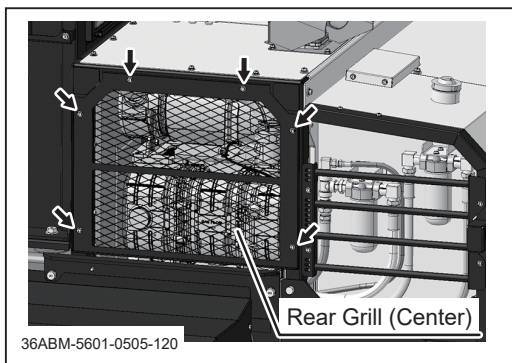

2. Remove six (6) bolts to remove the engine room rear grill (center).

Operator Side Service Panel

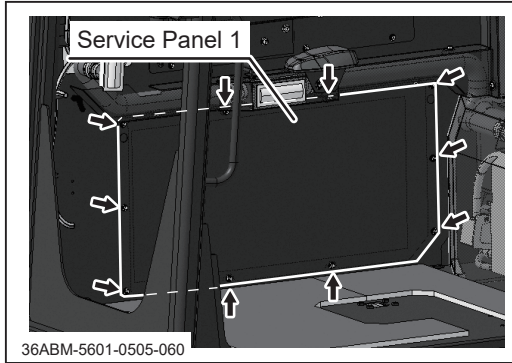

1. Remove ten (10) bolts to remove the operator side service panel 1.

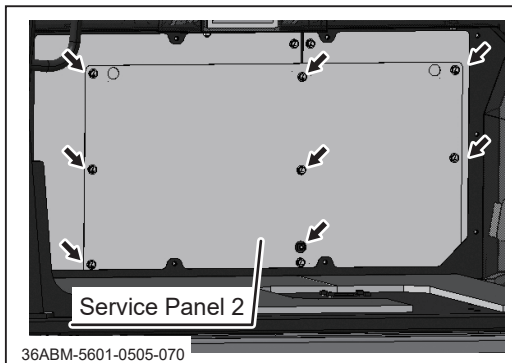

2. Service panel 2 is located inside the service panel 1. Remove eight (8) bolts to remove the operator side service panel 2.

Radiator Fan Shroud

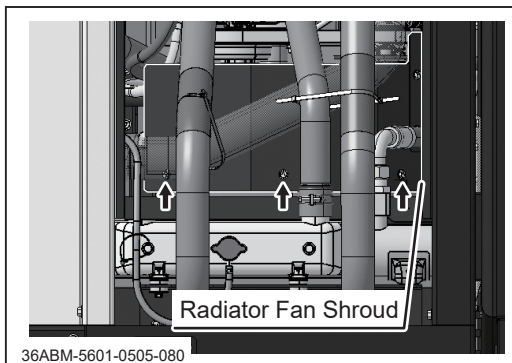

1. Open the engine hood.
2. Remove three (3) bolts and three (3) nuts to remove the radiator fan shroud.

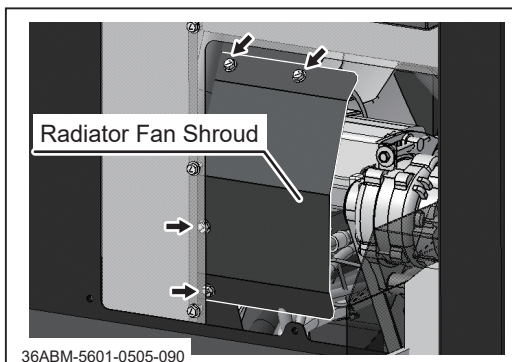

3. Open the side service door.
4. Remove four (4) bolts and four (4) nuts to remove the radiator fan shroud.

Engine

⚠ WARNING

- Always stop the engine and remove the key before servicing.
- An engine that has been running is very hot. Allow the engine to cool before servicing, or severe burns can result.
- Keep fire and spark away when servicing the engine or handling fuel.

Engine Oil

NOTICE

- Make certain to fill the engine with correct grade of oil to the specified level. Insufficient amount or wrong grade of oil reduces performance and can cause permanent damage to the engine.
- Dispose of the drained oil properly. Check the national and local regulations for discarding engine oil.

NOTE

- To obtain correct reading, check oil level before starting, or wait about 10 minutes after stopping the engine to allow oil to drain back to the oil pan.
- Always check oil level on a level surface.
- Refer to the Operator's Manual for the Engine when servicing the engine.
- Oil to use and amount: see page 73.

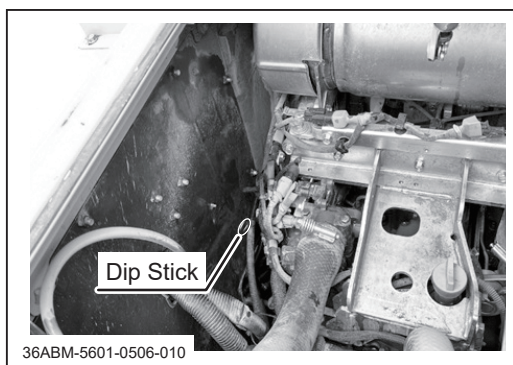

Inspecting

1. Park the machine on a level surface.
2. Open the engine hood.
3. Follow the instructions in the **Operator's Manual for the Engine** to inspect oil.
4. Close the engine hood.

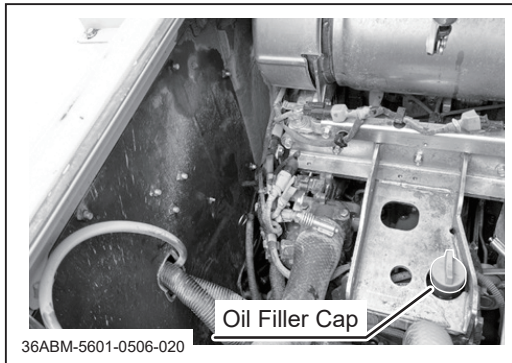

Filling

1. Open the engine hood.
2. Remove the oil filler cap.
3. Follow the instructions in the **Operator's Manual for the Engine** to fill oil.
4. Put the oil filler cap back in place and tighten it securely.
5. Close the engine hood.

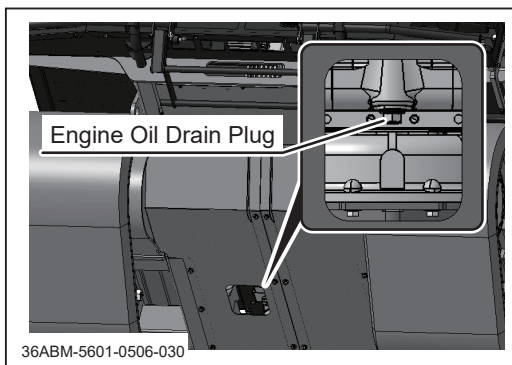

Changing

1. Open the engine hood.
2. Have an appropriate oil drain pan.
3. Remove the oil drain plug to drain oil.
4. Clean the drain plug and put it back in place and tighten it securely.
5. Fill specified amount of correct oil into the filler.
6. Close the engine hood.

NOTE

- **Oil capacity: 14.8L**
- **Oil to use: Diesel Engine Oil, API rating CJ-4 or CK-4, SAE index 10W-30**
- **Removing the oil filler cap helps drain oil faster.**

Oil Filter

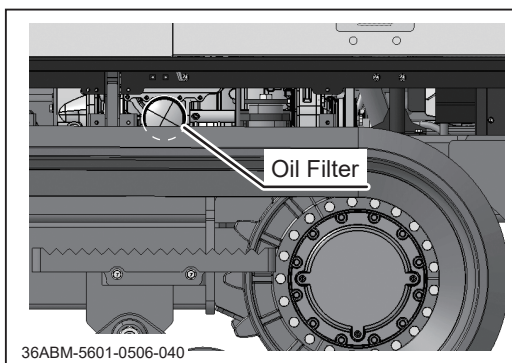

1. Remove the engine room side cover (1) (page 78).
2. Drain engine oil.
3. Follow the instructions in the **Operator's Manual for the Engine** to change the oil filter cartridge.
4. Fill oil.
5. Reinstall the engine room bottom cover.

Air Cleaner

NOTICE

- Clean air cleaner element regularly. Dirty cleaner element reduces engine performance and life.
- Replace cleaner element if damaged.

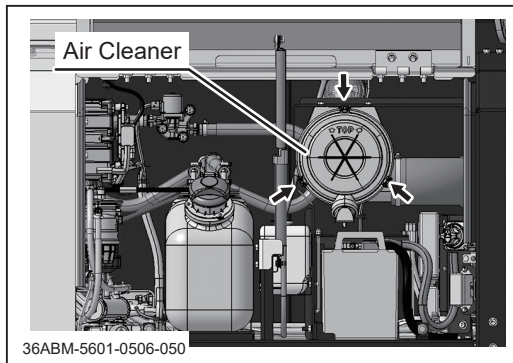

1. Open the side service door.
2. Undo the spring hooks to remove the air cleaner lid.

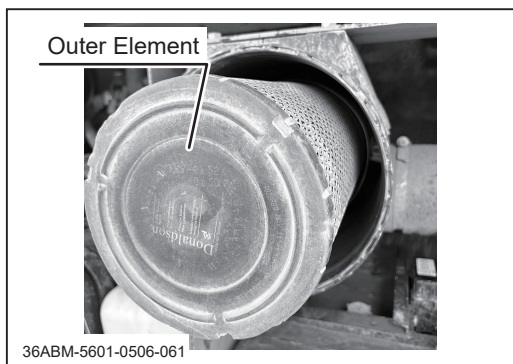

3. Follow the instructions in the Operator's Manual for the Engine to inspect, clean, or change the air cleaner element.
4. Close the side service door.

Coolant

NOTICE

- Do not open the radiator cap when the engine or radiator is hot. Opening cap when they are still hot can release boiling coolant and cause severe burns. Wait for the engine to cool after operation (about 30 minutes) before opening.
- Take extreme care when handling the coolant; antifreeze solution is inflammable. Avoid exposure to open flame. It is also toxic. If coolant is caught in the eye, wash the eye clean with running water and consult a physician immediately.
- Dispose of the drained coolant properly. Check the national and local regulations.

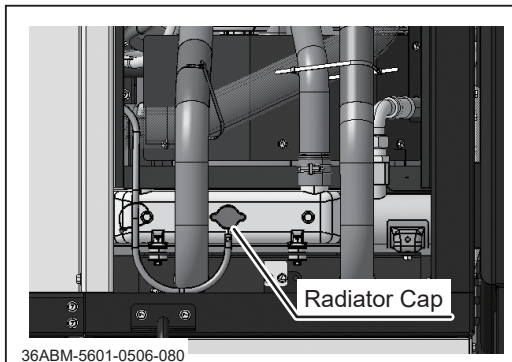
**Inspecting/Filling**

1. Remove the engine room bottom cover.
2. When the engine is cold, check engine coolant level in the reservoir tank. If the level is below the [FULL] mark, add water.
3. Open the radiator cap.
4. Check engine coolant level. If the level is low, add water.
5. Put the radiator cap back in place.
6. Close the engine hood.

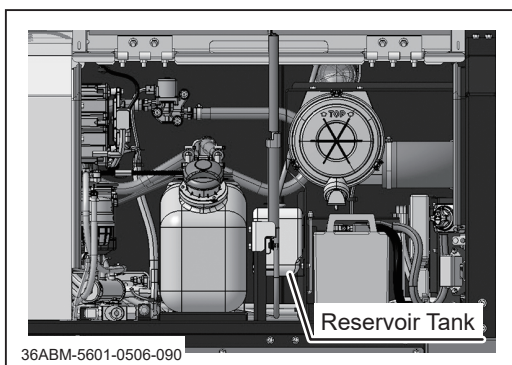
**NOTE**

- When coolant temperature warning light is lit, it may mean the coolant level is low. Immediately inspect and add water as necessary.

Ambient Temperature	Antifreeze Mixture
-10 °C	30%
-15 °C	35%
-20 °C	40%
-25 °C	45%
-30 °C	50%
-35 °C	55%
-40 °C	60%

* The value for the ambient temperature is 5°C lower than the actual minimum temperature.

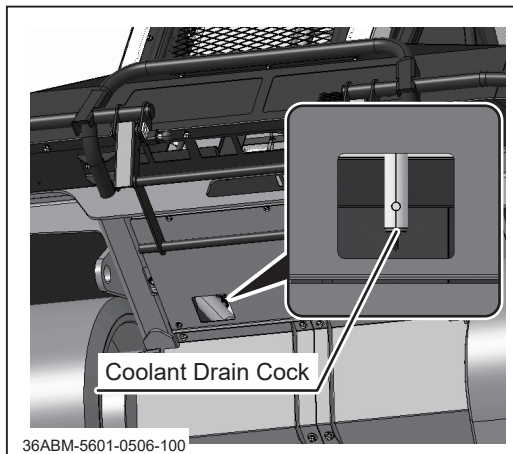

Antifreeze Mixture (Reference)

When this machine is shipped from the factory, it is filled with a mixture of 50% antifreeze and 50% water. To prevent coolant from freezing, use a mixture of water and antifreeze determined by the minimum temperature in the operation area using the table on the left.

NOTE

- **Antifreeze to use: Long Life Coolant (LLC).**
- **Use pure water to make antifreeze mixture.**

Changing

1. Have an appropriate drain pan big enough to hold all the coolant.
2. Remove the radiator cap and reservoir cap.
3. Open the drain cock under the machine.
4. Drain coolant. Then clean inside the radiator.
5. Close the drain cock.
6. Fill the radiator and the reservoir with antifreeze mixture.
7. Put the radiator cap and reservoir cap back in place.

NOTE

- **Coolant Capacity: 15L, reserve 1.1L**
- **Removing radiator cap helps drain the coolant.**

Fan Belt

NOTE

- Adjust belt tension properly. Improperly tensioned belts can reduce performance and its service life.

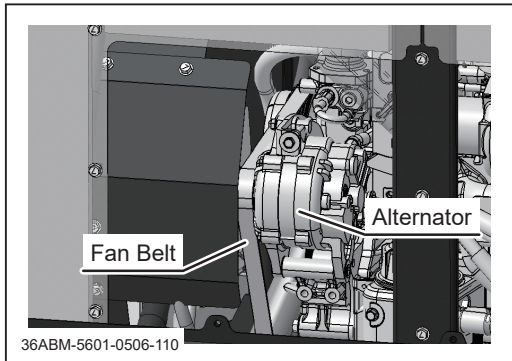

Inspecting/Adjusting

1. Remove the operator side service panel.

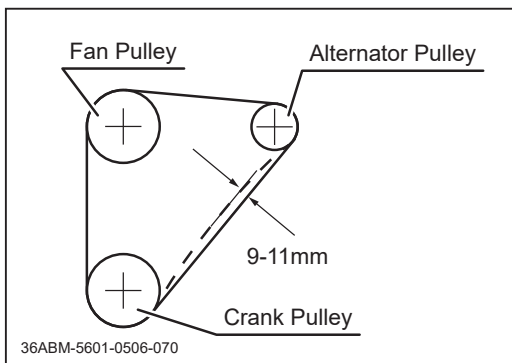

2. Press the middle of the fan belt with a finger to check tension.
Deflection shall be between 9mm and 11mm with a force of 59 - 69N (6 - 7kgf).
3. If deflection is not within that range, loosen the alternator mounting bolts and move the alternator to adjust tension.

NOTE

- For more details, see the Operator's Manual for the Engine.

4. Tighten mounting bolts.
5. Reinstall the operator side service panel.

DPF Regeneration

⚠ CAUTION

- When the display automatically changes to the DPF manual regeneration screen, and the DPF warning buzzer is sounding, perform manual DPF regeneration. Failure to do so can cause a malfunction.

⚠ CAUTION

- Fire hazard. Make sure that there are no combustibles around the exhaust pipe when performing manual regeneration.
- Do not perform manual regeneration in a poorly ventilated area; carbon monoxide poisoning can result.
- DPF regeneration takes about 15-20 minutes and will be canceled if 2 of the following conditions 1 - 4 are missed.

DPF Manual Regeneration Conditions

Parking Switch Input(On)	OK 1
Coolant Tempature(>65degC)	OK 2
Throttle Position (0%)	OK 3

- 1.Press the parking brake switch [ON] and move the lock lever to the [PARKING] position.
- 2.Run the engine to raise the engine coolant temperature above 65 deg C (149 deg F).
- 3.Move the throttle lever to the [SLOW] position.
- 4.Press the DPF Manual Regeneration Switch to begin regeneration.



DPF Manual Regeneration Icon

36ABM-5601-0506-120

When DPF manual regeneration is needed, the above screen is shown automatically in the LCD 1. When performing manual DPF regeneration, perform the following procedure so that all the items above will be [OK]. In case you choose not to perform DPF manual regeneration immediately, press the [esc] button on the LCD1 to return to the home screen.

When you are back in the home screen, the DPF Cleaning Indicator is blinking. With the DPF Cleaning indicator blinking, press the DPF switch (the second multifunction button from the left) to go back to the above screen.

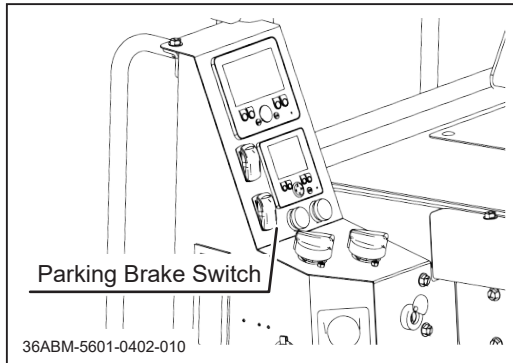

1. Press the parking brake switch [(P)] to engage parking brake.

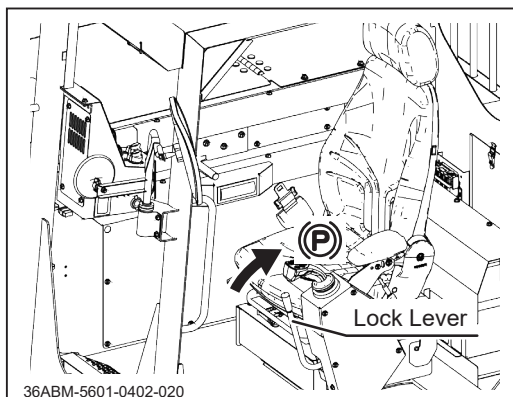

2. Pull up the lock lever to [(P) (parking)] position.

NOTE

- [Parking Switch Input (On)] (1) should turn to [OK].

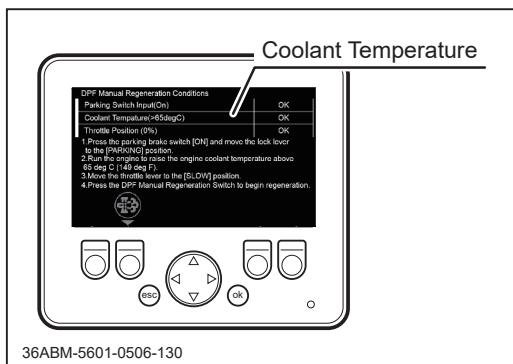

3. Start the engine and run until the coolant temperature reading gets above 65°C.

NOTE

- [Coolant Temperature (>65degC)] (2) should turn to [OK].
- If it is well below 65 degrees, raise the engine speed.

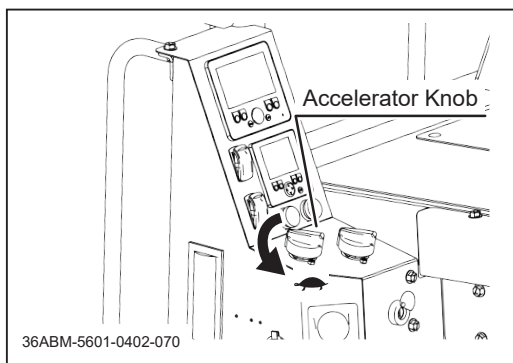

4. Once the coolant temperature gets above 65°C, turn the accelerator knob to [(SLOW)] position.

NOTE

- [Throttle Position (0%)] (3) should turn to [OK].

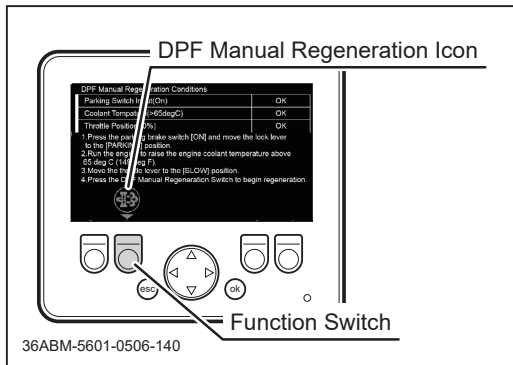

- When these three items becomes [OK], DPF Manual Regeneration icon flashes. Press the function switch directly below the icon to begin manual regeneration.



NOTE

- When regeneration starts, the buzzer beeps and [DPF Cleaning Now...] sign is shown.

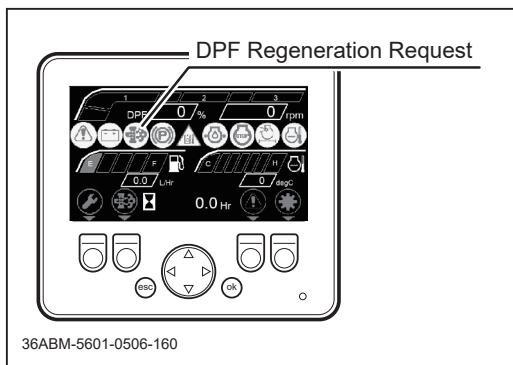

- When regeneration is done, the home screen is shown in the LCD 1. Make sure the DPF Regeneration Request icon is not highlighted.

Urea SCR (Selective Catalytic Reduction) System

⚠ WARNING

- Always stop the engine when filling DEF (Diesel Exhaust Fluid).
- Although urea water is nonflammable, care should be taken because it produces ammonia gas in the event of a fire.

CAUTION

- If urea water gets on hands, feet, or other parts of the body, flush with plenty of water. If it gets into eyes, flush with tap water for at least 15 minutes and seek medical attention immediately if discomfort is felt.
- Use appropriate protective equipment when handling urea water. Do not use cotton gloves or other items whose fibers may contaminate urea water. Wash hands with water after work is done.
- Do not operate the battery cutoff switch or turn off the power while the ACU running lamp is on after the engine is stopped. The DEF pump will run for about 10 minutes to collect the urea water in its path to the DEF tank.
- Do not use non-compliant urea water. Do not mix with the compliant urea water with other substances, including water. The SCR system and engine failure can result.
- If you filled the tank with non-compliant urea water or urea water containing foreign substances, do not turn on the key, as this can cause damage to the SCR system and engine. Contact your dealer.
- The life of urea water varies depending on temperature, and a rise in temperature will greatly reduce its life. Store urea water in a container at temperatures below 30°C.
- The urea water freezes below -11°C. Do not fill the tank to the brim as urea water expands when it freezes, and the tank can be damaged. Also, do not store urea water in its container in a place that gets below that temperature, as the container can be broken.
- Keep the container tightly closed in a well-ventilated place out of direct sunlight.
- If urea water is spilled, wipe it off and wash with water.
- For details, refer to the instruction manual of the urea water manufacturer.

NOTE

- Urea water must be replenished before operation as it is injected into the exhaust gas as the engine runs. When refilling, the machine needs to be parked on a level ground.
- Use urea water that meets or exceeds the quality requirements of ISO 22241 or JIS K 2247-1 standards. We recommend the use of AdBlueR (VDA registered trademark of the Association of German Automobile Manufacturers).
- When disposing of urea water, follow the national and local laws and regulations.

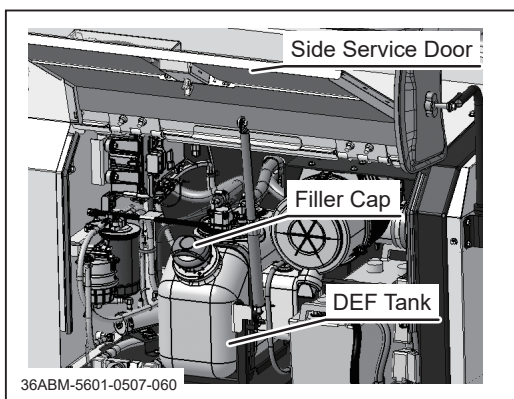

1. Open the side service door.

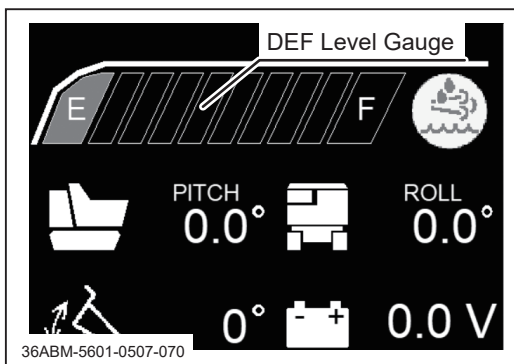

2. While checking the DEF level gauge, slowly fill the DEF tank with the compliant urea water. (DEF tank capacity: 20L)
3. Close the filler cap firmly.
4. Close the side service door.

Fuel System

⚠ WARNING

- Always stop the engine when servicing the fuel system.
- Fuel is highly flammable. Keep fire and spark away when servicing the fuel system or handling fuel. If fuel is spilt, wipe immediately.

NOTICE

- Dispose residual fuel in fuel filter or drained fuel or water properly. Check the national and local regulation for discarding such fluids.

Fuel Filter Cartridge

NOTICE

- Use only the genuine fuel filter. Non-genuine filter can damage the engine.

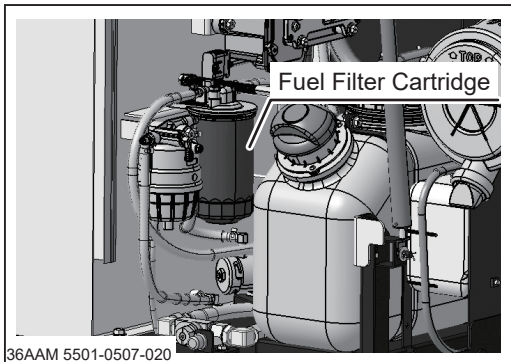

1. Open the side service door.
2. Remove the radiator fan shroud.
3. Using an oil filter wrench, remove the fuel filter cartridge.

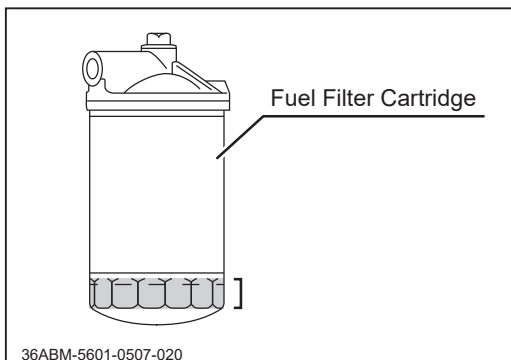

NOTE

- Apply the wrench in the shaded area in the illustration.

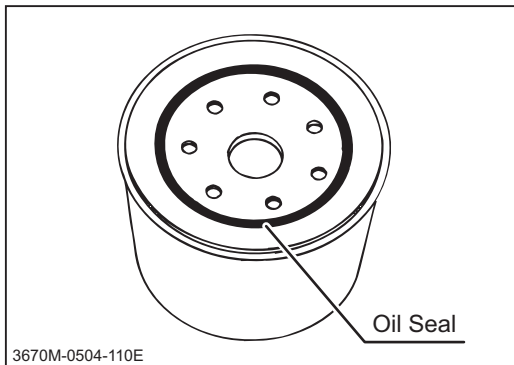

4. Apply a thin coat of new oil on the oil seal on the new fuel filter cartridge.
5. Install the fuel filter cartridge. Tighten it fully by hand.

NOTE

- Do not use oil the filter wrench when installing the filter.

6. After installation, bleed air in the fuel system.
7. Close the side service door.

Bleeding Air in the Fuel System

⚠ CAUTION

- Open the air bleed cock on the fuel injection pump only when bleeding air from the fuel system. Keep it shut all the other times; Engine may stall.

NOTE

Bleed air when air enters the fuel system

- After changing the fuel filter or disconnecting fuel line.
- After running the engine until fuel tank is completely dry.
- After a long-term storage.

When air is in the fuel system, the engine cannot run.

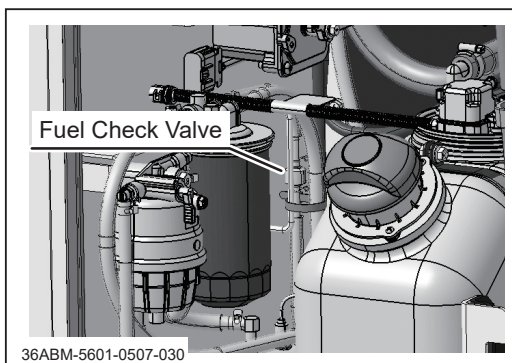

1. Fill fuel in the tank.
2. Turn the main switch on and wait for a few minutes.
3. Start the engine and run it for a minute.

NOTE

- If the engine cannot be started, keep the main switch on for an additional few minutes.

- Air is bled through the check valve; turning the main switch on automatically bleeds air in the fuel system.

NOTE

- If air is in the fuel system, a sound is heard through the check valve. Once it is gone, bleeding is done.

Draining Water Separator**NOTE**

- Water separator collects water and impurities in the fuel. When the red float in the water separator cup goes up, drain the water separator as described below.

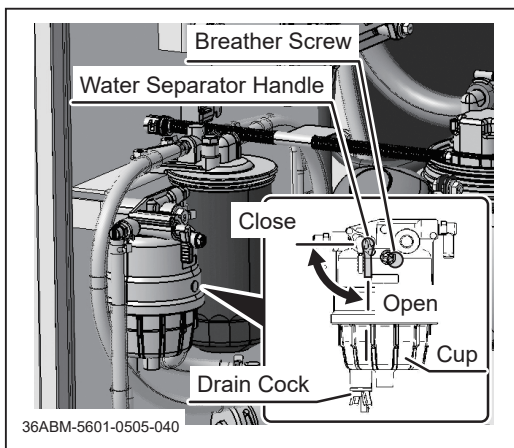

- Turn the water separator handle to the [CLOSE] position.
- Loosen the drain cock and breather screw to drain water and impurities.
- Tighten the drain cock and breather screw.
- Turn the water separator handle to the [OPEN] position.
- Bleed air from the fuel system.

NOTE

- Refer to the Operator's Manual for the Engine for other engine service items.

Draining Water From Fuel Tank

⚠ WARNING

- Keep fire and spark away when handling fuel.
- When emptying the tank, use only the pump designed for diesel fuel. Wrong kind of pump can catch fire.

NOTICE

- Dispose of the drained oil properly. Check the national and local regulations for discarding engine oil.

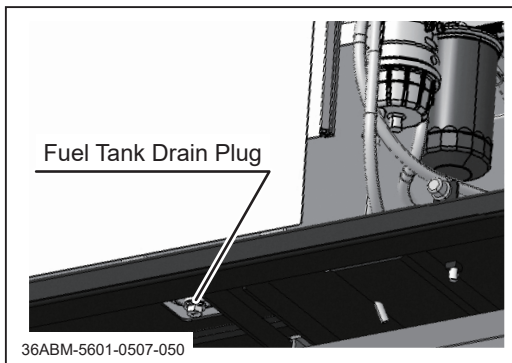

1. Use pump to empty fuel tank.
2. Have an appropriate oil drain pan to catch remaining fuel and water.
3. Remove the fuel tank drain plug to drain remaining fuel with water and sediments in the tank.
4. Install the fuel tank drain plug.
5. Fill fuel in the tank and bleed air from the fuel system.

Drive Train

WARNING

- Stop the engine when servicing the drive train.
- Allow the machine to cool off before servicing. The machine is very hot after operation and can pose a burn hazard.

Tracks

WARNING

- Make certain to adjust track tension properly. Improperly tensioned tracks can wear or come off, resulting in property damage, serious injury or death.
- When loosening track adjuster valve, loosen slowly and gradually so that it will not come off. Track adjuster cylinder is under pressure, and if adjuster valve comes off, it can be projected out, possibly causing injury or damage.
- Always unload machine before jacking up.

CAUTION

- Track is very heavy. Handle it with care.

NOTE

- During the initial hours of use, track tends to get broken in and stretch more than usual. Inspect often and adjust as necessary.
- Track tension gets loose during its use-life for wear or bedding of the sprocket and track. Inspect and adjust regularly.

Inspecting

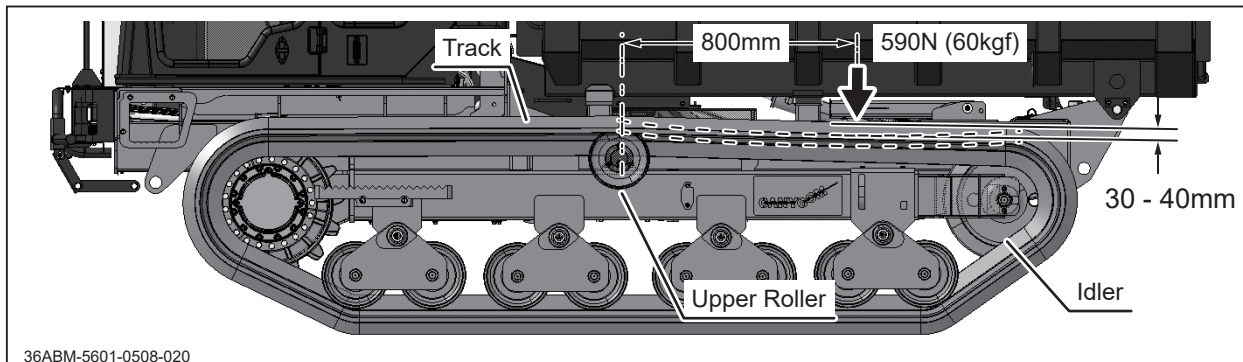

1. Park the machine on a level ground.
2. Inspect the track tension; press the track between the upper roller and the idler with a force of 590N (60kgf) and measure the deflection of the track.

NOTE

- Track deflection: 30 and 40mm with a force of 590N (60kgf).

3. If the amount of deflection is not within this range, adjust.

Adjusting

1. Park the machine on a level ground.
2. Remove the track adjuster valve cover.
3. Attach a grease pump to the track adjuster valve and pump grease into the track adjuster cylinder until the above mentioned deflection is between 30 and 40mm.
4. Remove the grease pump and install the valve cover.

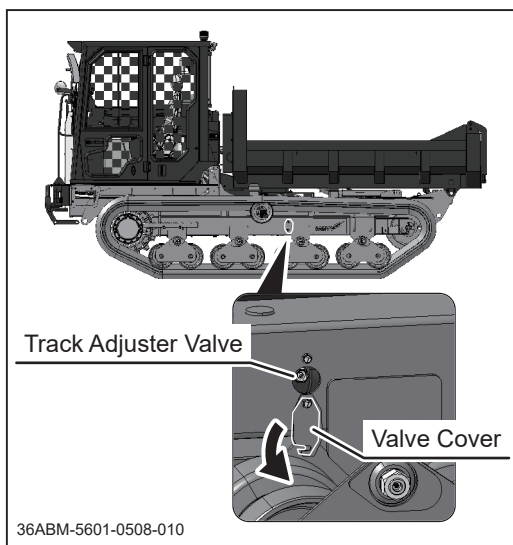

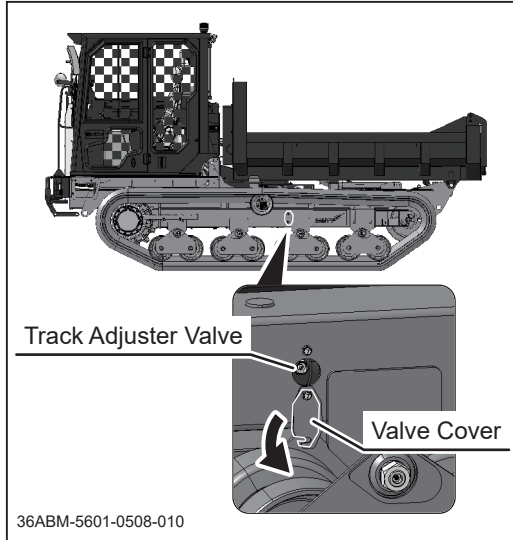

Replacing/Installing

1. Park the machine on a level ground.
2. Remove the track adjuster valve cover.
3. Slowly loosen the track adjuster valve to let grease come out around the valve to reduce pressure inside the rack adjuster cylinder.
4. Remove the valve.
5. Push the idler wheel fork in, towards the front of the machine.
6. Remove the track.
7. Fit the new track, first it on the sprocket, then on the idler.
8. Reinstall and tighten the valve securely. Make sure not to have the valve O-ring get caught.

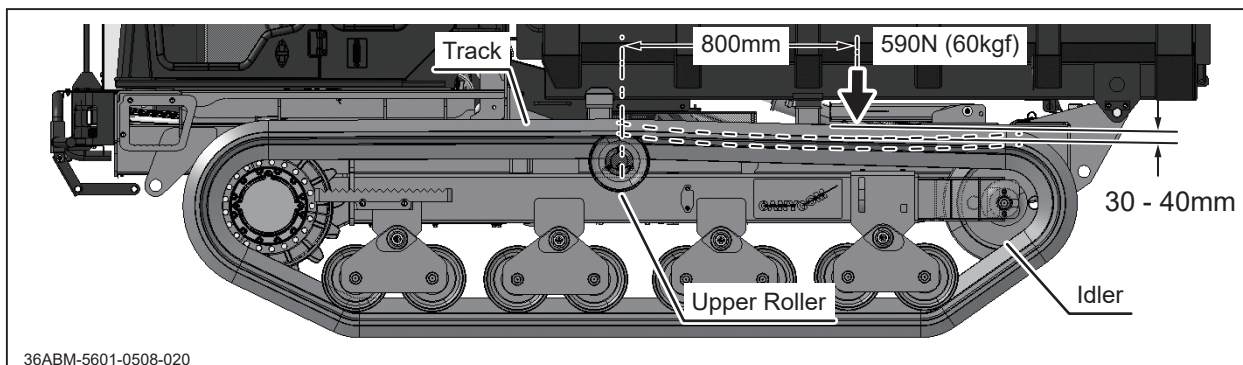

9. Attach a grease pump to the track adjuster valve and pump grease into the track adjuster cylinder, until the above deflection is between 30 and 40mm.
10. Remove the grease pump, install the valve cover, and lower the machine.

HST (Hydrostatic Transmission) Oil

⚠ WARNING

- Always stop the engine when servicing.
- A machine that has been running is very hot. Allow the machine and oil to cool before servicing, or severe burns can result.

NOTICE

- When hydraulic oil level gets low, air can enter the hydraulic system and impairs its performance. Make certain to fill the hydraulic system with correct grade of oil to the specified level.
- Dispose of the drained oil properly. Check the national and local regulations for discarding engine oil.

NOTE

- HST oil is used for driving as well as for the hydraulic apparatus.
- To obtain correct reading, check oil level before starting the engine. Hot oil expands in volume, and correct reading cannot be obtained.
- Always check oil level on a level surface.
- Change suction filter when changing hydraulic oil.
- Oil to use and amount: see page 73.

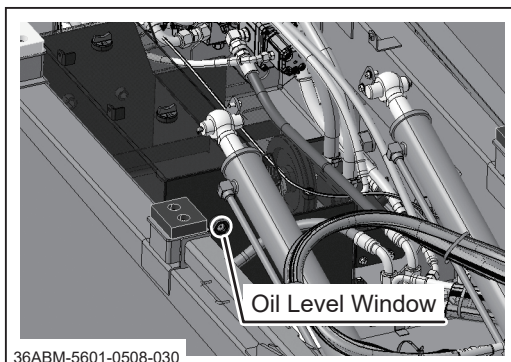

Inspecting/Filling

1. Park the machine on a level ground.
2. Raise the bucket fully and secure it with the safety props. (On the straight dump model)

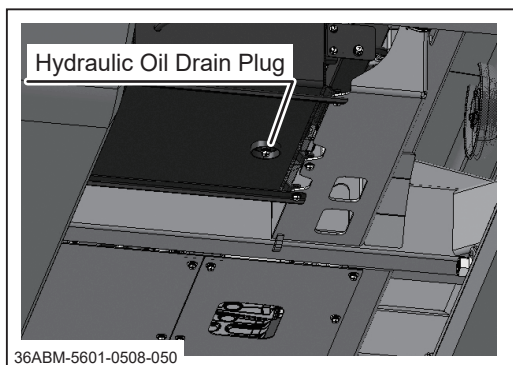
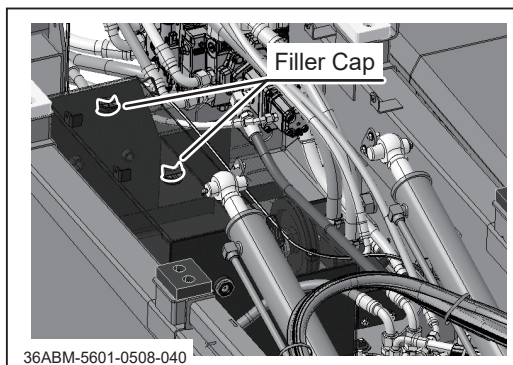
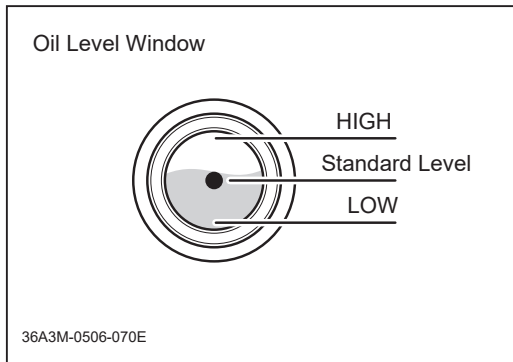

3. Visually inspect the oil level window for oil level and condition.

4. If the level is low, open the filler cap and fill oil. Put the filler cap back in place.
5. Start and run the engine for a while to circulate oil, then, stop the engine.
6. Visually inspect fluid level to be within the oil level window.
7. Undo the safety props and lower the bucket.

NOTE

- On the base model with equipment on the back, follow the equipment supplier's instructions.

Changing

1. Park the machine on a level ground.
2. Have an appropriate oil drain pan.
3. Remove the hydraulic oil drain plug to drain oil.
4. Install the drain plug.

NOTE

- Replace both the suction filter elements and line filter cartridge when hydraulic oil is changed.

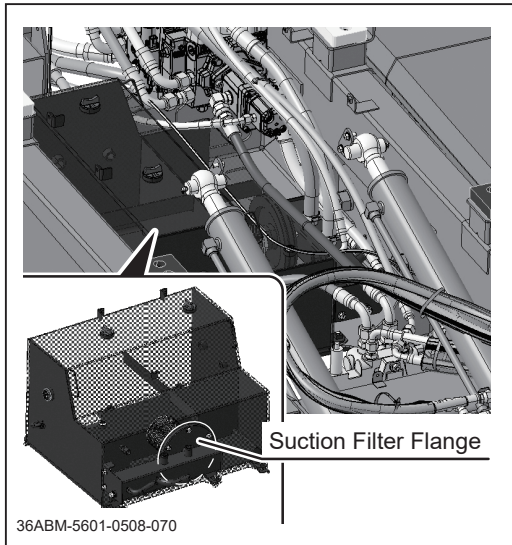

5. Raise the bucket and secure it with the safety props.
6. Remove the suction filter flange from the oil tank.
7. Remove the old filter element from the flange and install a new one.
8. Reinstall the suction filter flange.

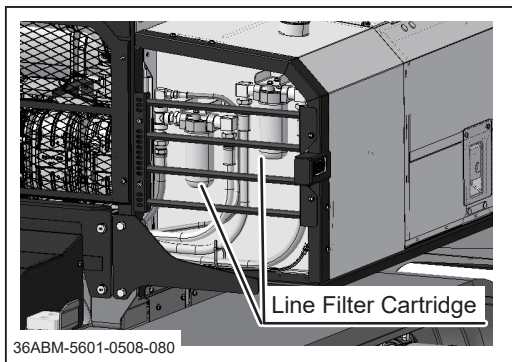

9. Remove the rear grill.
10. Remove the line filter cartridge with an oil filter wrench.
11. Have a new line filter cartridge ready. Apply clean hydraulic oil on the cartridge oil seal evenly.
12. Screw in the new line filter cartridge. Tighten it by hand until the cartridge is firmly in place.

NOTE

- Do not damage the oil seal. If the oil seal is damaged, use a new filter cartridge.
- Do not use the filter wrench when tightening the filter cartridge. Tighten it by hand.

13. Perform the same on the other line filter cartridge.
14. Reinstall the rear grill.

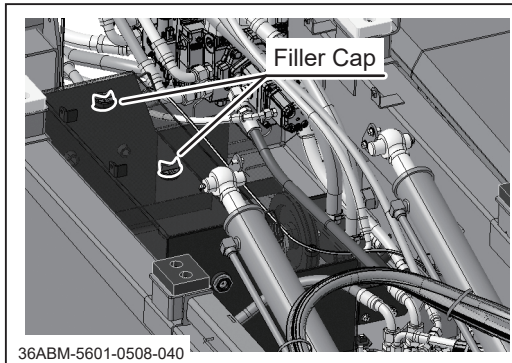

15. Open the filler cap and fill oil until the oil level is within the oil level window. Put the filler cap back in place.
16. Start the engine to circulate oil. Watch for leaks.
17. Stop the engine and inspect the oil level. If it is low, add oil until it is within the oil level window.
18. Undo the safety props and lower the bucket.

Travel Motor Oil

⚠ WARNING

- Always park the machine on a level surface and block the tracks with chocks when working under the machine.

NOTICE

- Dispose of the drained oil properly, according to the national and local regulations.

NOTE

- Oil to use and amount: see page 73.

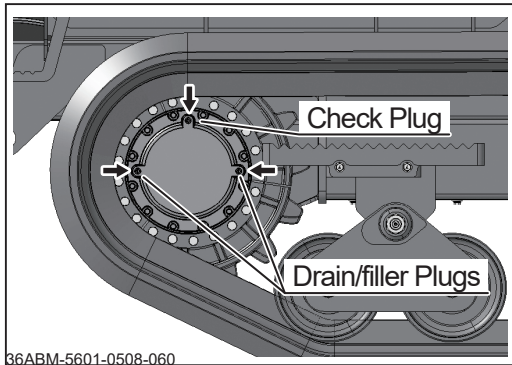

Changing

1. Park the machine on a level ground
2. Drive the machine so that one of the drain/filler plug is at the top, another at the bottom, and the check plug is at the side (see illustration).
3. Remove all the plugs to drain oil.
4. Once oil is drained, reinstall the drain plug to the bottom port.
5. Fill oil into the drain/filler port at the top until oil comes out of the check port at the side.
6. Reinstall the drain/filler plug to the top port and check plug to the check port.

NOTE

- Oil to use: Gear oil, API rating GL-4, SAE index 90.

Compressor Belt

NOTE

- Loose belt can slip and shorten belt life.
- Stop the engine before inspection or adjustments.

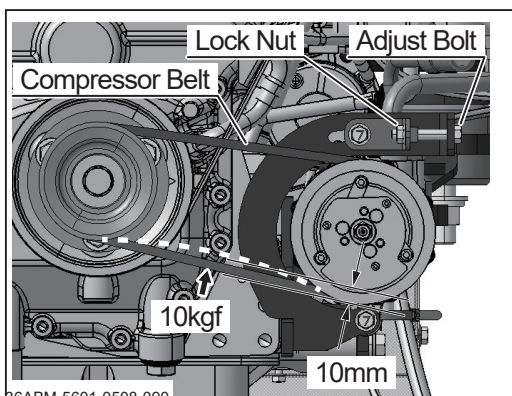

1. Remove the service panel (1), (2) and Radiator Fan Shroud (2).
2. Press the compressor belt with a finger (approx. 10 kgf) and check the tension of the belt.

NOTE

- Amount of deflection: approx. 10 mm

Cabin

Cleaning Mirrors and Cameras

NOTICE

- Keep the rear view mirrors and the Around View cameras clean to avoid accidents.

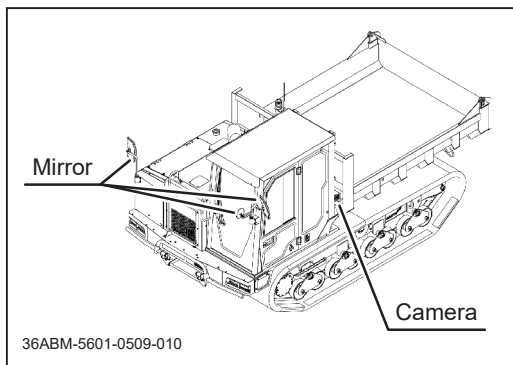

1. When the rear view mirrors or the Around View cameras get dirty, clean them

NOTE

- There are three Around View cameras as shown in the illustrations.

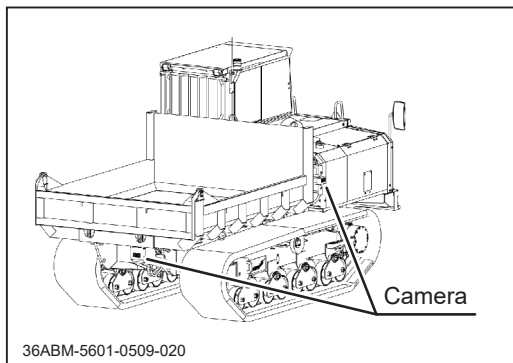

Electrical System

WARNING

- Always stop the engine and turn the main switch to [ (OFF)] position, and disconnect the negative (-) terminal of battery when servicing the electrical system.
- Do not work on the electrical system with wet hands. Electric shock can result.

Battery

WARNING

- Never use or charge battery when the fluid level is below the lower limit. Charging battery with insufficient fluid can shorten battery life or cause an explosion.
- Battery fluid (diluted sulfuric acid) is corrosive and causes severe burns. Be extremely cautious when handling battery fluid. If battery fluid is spilled on clothes, immediately rinse with plenty of water. If spilled on skin or in an eye, immediately rinse with plenty of water and promptly consult a physician.
- Explosion hazard. Keep open flame or spark away from the battery. Hydrogen gas generated during charging is extremely explosive.
- Use wet cloth to clean the battery. Dry cloth can generate static electricity, which can cause explosion.
- Do not touch the battery terminals. Electric shock can occur.
- Always disconnect the negative (-) terminal first, and connect the positive (+) terminal first. Disconnecting or connecting in the opposite order can cause a short circuit.
- When installing the battery, make certain to connect the positive (+) and negative (-) terminals to their respective original positions. Avoid contact between terminals and other surrounding parts.

⚠ CAUTION

- Never fill battery fluid beyond the [UPPER LEVEL] line. Battery fluid can spill and cause damage to the machine or personal injury.

NOTICE

- Always remove the battery from the machine before charging. Failure to do so can cause damage to the electrical components and wiring.
- Follow the battery charger user's manual when charging.

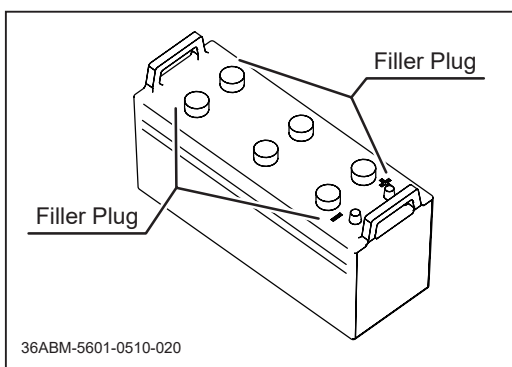
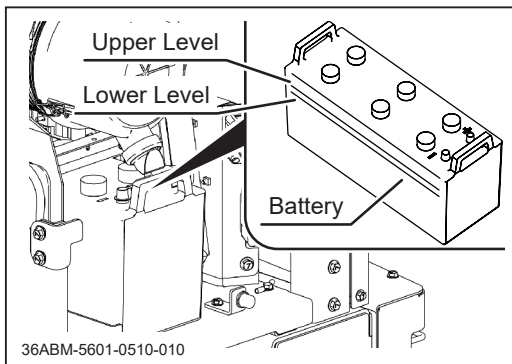
**Inspecting/Filling**

1. Park the machine on a level ground. Open the side service door.
2. Visually inspect that the battery fluid level is between the "Upper Level" and "Lower Level" lines. If the fluid level is below the "Lower Level," fill.
3. Remove the battery filler plugs and add distilled water up to "Upper Level" line.
4. Reinstall the filler plugs.
5. Close the side service door.

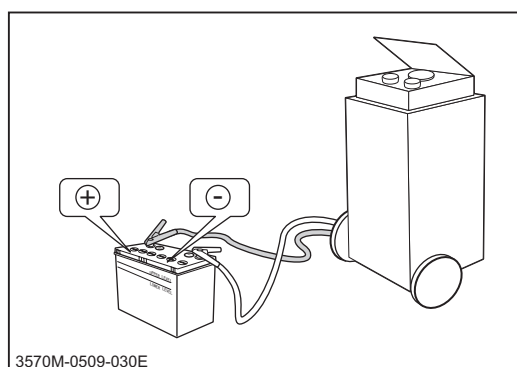
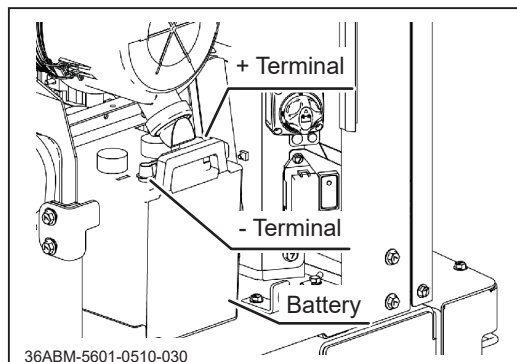

Charging

1. Park the machine on a level ground. Open the side service door.
2. Remove the battery from the machine.
3. Remove all the battery filler plugs.
4. Follow the instructions in **the battery charger user's manual** to charge the battery.
5. When the battery is fully charged, put the filler plugs back in place.
6. Reinstall the battery. Close the side service door.

NOTE

- **Rapid charging is only an emergency measure. This method uses a large amount of current to compensate the lost charge in a short time. However, the battery needs to be fully charged in the ordinary method for a longer service life.**

Fuses

NOTICE

- If a fuse blows, investigate the cause and repair it before replacing the fuse.
- Always replace a fuse with the one of the correct rating.

NOTE

- Fuses are provided to protect the electrical circuit from abnormal current caused by short circuit or a damage in an electrical component. If an electrically-related problem occurs, inspect the related fuse.

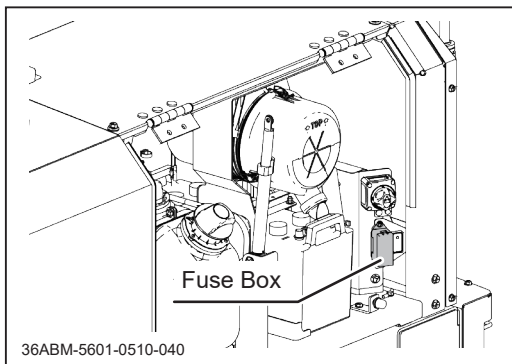
**Main Fuse Box**

1. Open the side service door.
2. Open the fuse box lid.
3. Locate the blown fuse and replace it with a new one of the correct rating.
4. Put the lid back in place.
5. Close the side service door.

Spare	
5A	10A
USB Socket/ Option Power Supply	Vehicle ECU/ Horn/Buzzer
20A	10A
Solenoid Valve	Lights/ Alternator/LCD
20A	10A
EGR	Engine ECU
5A	5A
Nox Sensor/ Tank Sensor	ACU
10A	20A
Air Conditioner/ Wiper	Main Switch
30A	5A

36AB 5018 000

36ABM-5601-0510-071

NOTE

- Vehicle ECU/Horn/Buzzer: 10A
- Lights/Alternator/LCD: 10A
- Engine ECU: 5A
- ACU: 20A
- Main Switch: 5A
- Accessory Socket/Optional Power Supply: 20A
- Solenoid Valve: 20A
- EGR: 5A
- Nox Sensor/Tank Sensor: 10A
- Air Conditioner/Wiper: 30A

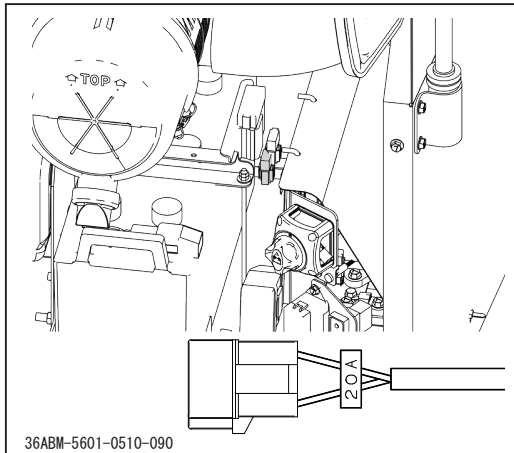

Air Conditioner Fuse

1. Open the side service door.
2. Open the lid of the Fuse housing.
3. Locate the blown fuse and replace it with a new one of the same rating.
4. Put the lid back in place.
5. Close the side service door.

NOTE

- Air Conditioner: 20A

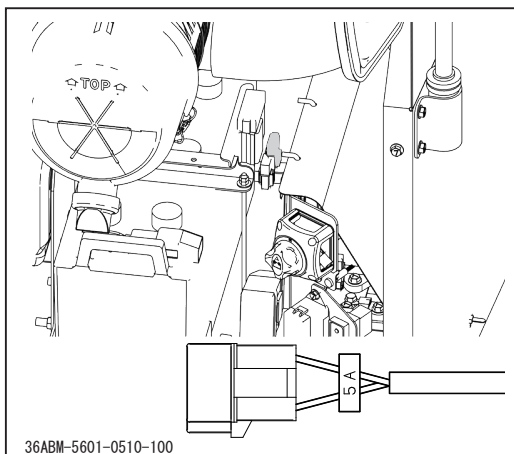

CCV Fuse

1. Open the side service door.
2. Open the lid of the Fuse housing.
3. Locate the blown fuse and replace it with a new one of the same rating.
4. Put the lid back in place.
5. Close the side service door.

NOTE

- CCV: 5A

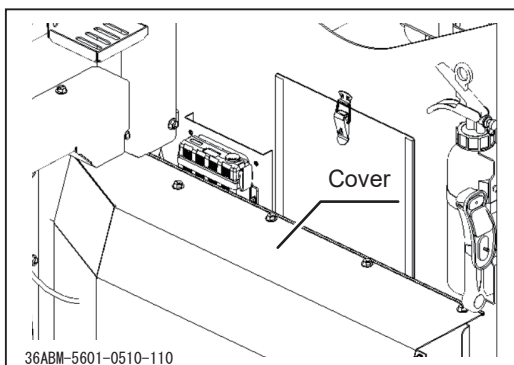

Around View Fuse

(for the machine with Around View)

1. Remove the cover in the cabin behind the seat.

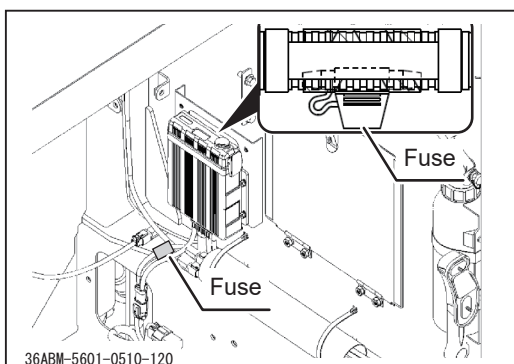

2. Locate the blown fuse and replace it with a new one of the same rating.
3. Put the cover back in place.

NOTE

- Around View: 5A

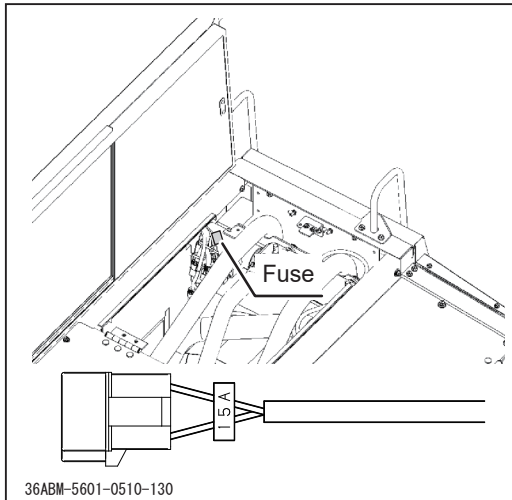

Audio Fuse

1. Open the engine hood.
2. Locate the blown fuse and replace it with a new one of the same rating.
3. Close the engine hood.

NOTE

- **Audio: 15A**

Slow Blow Fuses

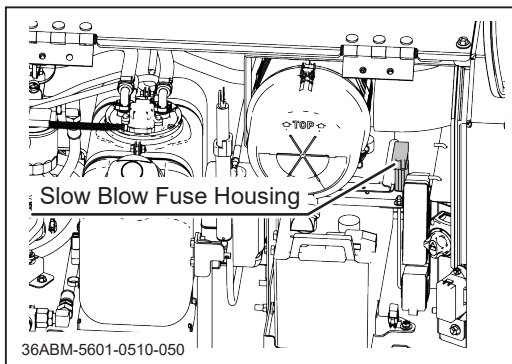

1. Open the side service door.
2. Open the lid of the Fuse housing.
3. Locate the blown fuse and replace it with a new one of the same rating..
4. Put the lid back in place.
5. Close the side service door.

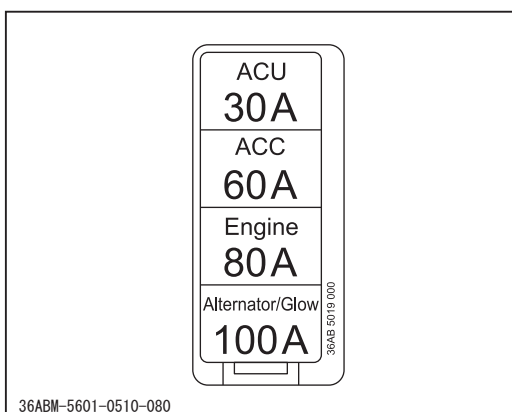

NOTE

- **ACU: 30A**
- **ACC: 60A**
- **Engine: 80A**
- **Alternator/Glow: 100A**

Lights

⚠ CAUTION

- Turn off the battery cutoff switch before replacing the head light, work light, or rotatin light.

1. Check the fuse. If a fuse is blown, replace.
2. Replace the light unit that is not working.

Air Conditioner (AC) Unit

⚠ CAUTION

- Stop the engine before servicing the AC unit. There is a fan and a motor inside the unit. They run fast and pose a cut hazard.

NOTICE

- You may need to have a licence or a qualification to service the air conditioner. Check your national and local regulations.
- Clean inside the AC unit regularly. Dirt can accumulate inside, affects its efficiency, and can result premature failure.

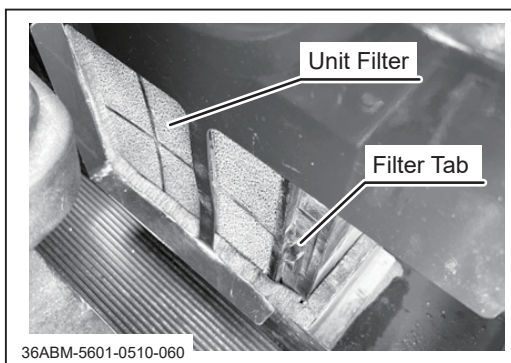

1. Remove the unit filter.
2. Tap the unit filter lightly to remove any debris.
3. Blow the inside of the unit with compressed air.
4. Install the unit filter.

After Use Care

NOTICE

- Do not wash the engine, control panel, electrical parts, or tank caps with air breather with running water; water can enter inside and cause rust or damage.
- Clean the machine after use; leaving dirt or foreign objects can cause damage.
- Do not attempt to move the machine when it becomes inoperable due to freezing.
- Dispose of the residual air spent fuel, oil, coolant, or other fluids, replaced filters, cartridges, damaged parts, etc. properly. There may be regulations for their disposal, and it can be unlawful to dispose them in a way other than prescribed by these regulations. Check the national and local regulations for discarding such materials.
- Wash the machine particularly thoroughly after use near the sea or in the areas where de-icing agent is used to wash off salt or other corrosive chemicals.

After Normal Use

1. Clean the machine; wash off dirt, mud, and other foreign matter after use.
2. If the machine is to be left outside, cover the machine with protective, water-proof covering after the machine is cooled off.

After Cold Weather Use

1. Clean the machine; wash off dirt, mud, and other foreign matter after use.
2. Park the machine on a paved or firm, dry surface or on a layer of lumber.
3. If the machine is to be left outside, cover the machine with protective, water-proof covering after it is cooled off.

Washing

⚠ WARNING

- High-pressure washer can be dangerous. Never point it to a person. Make sure no one is behind the machine when washing the machine with a high-pressure washer. Follow the instruction manual of the high-pressure washer and familiarize with its use.

NOTICE

- Never point the high-pressure washer or running water to the engine, electrical parts, control panel, or caps with a breather. Water can enter and cause damage.
- High-pressure washer can peel off the sticker labels.

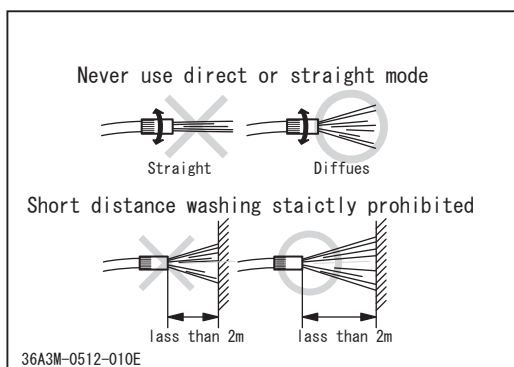

1. Set the washer nozzle (of a hose or a high-pressure washer) to diffuse mode. Never use direct or straight mode.
2. When washing the machine with a running water from a hose or with a high-pressure washer, keep enough distance from the machine (2 m (2.2 yd) or more with running water. With a high-pressure washer, refer to its instruction manual).

NOTE

- Water under high pressure can damage the wiring and insulation of the electrical components, which can result in damage, electrical shock, or fire.
- Water under high pressure can damage the hydraulic plumbing, which in turn can cause the hydraulic oil under very high pressure to escape and cause damage or severe injury.
- Water under high pressure can peel off sticker labels, paint and plating, or damage rubber, plastic, or glass parts.
- Water under high pressure can enter inside the engine, transmission, electrical parts, tanks, cabin, etc. to cause damages.



Storage

WARNING

- Fire hazard; do not store the machine where there is a possibility of ignition.

NOTICE

- Do not wash the engine or control panel with running water; water can enter inside and cause rust or damage.
- Clean the machine before storage; leaving dirt or foreign objects can cause rust or damage.
- Do not store the machine in a humid, dusty, or hot place.

1. Follow the instructions in **Parking** (page 44) to park the machine.
2. Turn the accelerator knob and the speed knob to [ (SLOW)] position and press the [ (parking brake)] switch.
3. Clean dirt off of the machine.
4. Follow the **Maintenance Schedule** (page 68) to perform scheduled services.
5. Wipe clean the steel parts with oiled cloth.
6. Grease the greasing points.
7. Change engine oil (page 81).
8. Completely drain engine coolant.
9. Clean the air cleaner element (page 83).
10. Completely drain the fuel tank.
11. Make sure the ACU lamp is not illuminated.
12. Turn the battery cutoff switch to the [ (OFF)] position. Service battery (page 105).
13. Cover the machine with protective, water-proof covering after the machine is cooled off.

NOTE

- Battery discharges even when it is not in use. A battery may hold charge for a few months, but it is a good practice to charge battery before it goes flat; it will extend the battery life.
- Refer to the Operation Manual for the engine, for detailed instructions on preparing the engine for storage.
- Before starting up the machine after storage, make sure to fill engine coolant and fill fuel and bleed air from the fuel system. After starting, check for leaks and drive slowly to make sure everything is in order.
- Do not turn off the battery cutoff switch when the ACU lamp is lit. Even with the key OFF, when the ACU lamp is lit, the urea in the pipe is being collected. Turning off the battery cutoff switch can cause a malfunction.

Troubleshooting

- If any malfunction or abnormal condition is found, immediately stop using the machine and take an appropriate measure according to the Troubleshooting chart below. If the malfunction or abnormal condition is not listed in the chart, or the suggested measure does not solve the problem, consult with your CANYCOM representative.
- Some corrective measures listed below require special knowledge and/or equipment. Please contact your CANYCOM representative in such a case.

Area	Malfunction	Possible Cause	Corrective Measure	Ref.
Engine	Engine does not start, or is difficult to start	Out of fuel.	→Fill fuel.	Page 26
		Air in fuel system.	→Bleed air.	Page 87
		Water in fuel.	→Drain water.	Page 88, 89
		Battery is discharged.	→Add battery fluid →Charge battery. →Replace battery.	Page 99
		Battery cable is disconnected.	→Connect battery cable.	
		Bad connection or breakage in the wiring.	→Please contact your CANYCOM representative.	
		Starter switch, relay or motor is defective.	→Please contact your CANYCOM representative.	
		Insufficient or wrong oil.	→Fill or change oil.	Page 75
		Other (other than the above).	→Please contact your CANYCOM representative.	
	Engine stalls	Out of fuel.	→Fill fuel.	Page 26
		Air in fuel system.	→Bleed air.	Page 87
		Cold engine.	→Warm up engine.	
		Other (other than the above).	→Please contact your CANYCOM representative.	

Area	Malfunction	Possible Cause	Corrective Measure	Ref.
Engine	Engine stops abruptly	Out of fuel.	→Fill fuel.	Page 26
		Piston seizure due to insufficient or bad oil.	→Please contact your CANYCOM representative.	
		Other (other than the above).	→Please contact your CANYCOM representative.	
	Engine does not stop	Electrical malfunction	→Please contact your CANYCOM representative.	
		Other (other than the above).	→Please contact your CANYCOM representative.	
	Idling is not stable	Insufficient intake air (clogged air cleaner).	→Clean or replace air cleaner.	Page 77
		Other (other than the above).	→Please contact your CANYCOM representative.	
	Poor power or acceleration	Bad fuel	→Change fuel.	
		Wrong oil (improper viscosity)	→Change to suitable oil.	Page 75
		Accelerator is not properly adjusted.	→Please contact your CANYCOM representative.	
		Insufficient intake air (clogged air cleaner).	→Clean or replace air cleaner.	Page 77
		Excessive load	→Reduce load.	
		DPF is clogged.	→Please contact your CANYCOM representative.	
		Other (other than the above).	→Please contact your CANYCOM representative.	
	Irregular noise or vibration from or around the engine	Loose engine mount.	→Tighten.	
		Other (other than the above).	→Please contact your CANYCOM representative.	
	Excessive oil consumption		→Please contact your CANYCOM representative.	

Area	Malfunction	Possible Cause	Corrective Measure	Ref.
Engine	Engine overheats	Insufficient amount of engine oil.	→Fill oil.	Page 75
		Insufficient amount of coolant.	→Fill coolant.	Page 78
		Radiator is clogged or blocked.	→Clean.	
		Other (other than the above).	→Please contact your CANYCOM representative.	
	Excessive fuel consumption	Leak in the fuel system.	→Please contact your CANYCOM representative for a repair.	
		Clogged air cleaner.	→Clean or replace air cleaner.	Page 77
		Other (other than the above).	→Please contact your CANYCOM representative.	
	Black smoke comes out of exhaust	Bad fuel.	→Change fuel.	
		Clogged air cleaner.	→Clean or replace air cleaner.	Page 77
		Other (other than the above).	→Please contact your CANYCOM representative.	
	White or blue smoke comes out of exhaust	Engine oil level is too high.	→Adjust the oil level.	
		Wrong oil (improper viscosity)	→Change to suitable oil.	Page 75
		Other (other than the above).	→Please contact your CANYCOM representative.	
	Accelerator lever does not move smoothly	Deformed or rusty linkage or wire.	→Please contact your CANYCOM representative.	
		Other (other than the above).		
Engine warning lights up	ECU or VCU error.	→Please contact your CANYCOM representative.		

Area	Malfunction	Possible Cause	Corrective Measure	Ref.
Drive Train	Machine does not move (forward, backward, turning) when the travel lever is in the corresponding position.	Parking brake is applied	→Release parking brake.	Page 33
		Excessive load	→Reduce load.	
		Insufficient or deteriorated HST Oil.	→Add or change fluid.	Page 93
		Other malfunction in the hydraulic drive system.	→Refer to the "Hydraulics" section	
	Other (other than the above).	→Please contact your CANYCOM representative.		
	Irregular noise or heat is observed at or around the track.		→Please contact your CANYCOM representative.	
Brake	Parking brake does not work well.	Problem in hydraulic system.	→Refer to the "Hydraulics" section	
		Other (other than the above).	→Please contact your CANYCOM representative.	
Hydraulic System	Dump does not operate normally. Vessel (bed) does not go up or go up very slowly.	Emergency Dump Valve is open. (The white line on the valve bolt is not vertical.)	→Turn the valve bolt clockwise so that the white line becomes vertical.	
	Hydraulic components (hydraulic motor, cylinder) does not work properly.	Insufficient or deteriorated hydraulic oil.	→Fill or change oil.	Page 93
		Hydraulic oil is contaminated	→Change oil.	Page 93
		Oil filter is clogged.	→Change filter.	Page 95
		Oil leaks	→Repair leak.	
		Insufficient discharge from hydraulic pump.	→Please contact your CANYCOM representative.	
		Other (other than the above).	→Please contact your CANYCOM representative.	

Area	Malfunction	Possible Cause	Corrective Measure	Ref.
Chassis	Track does not move smoothly.	Not properly adjusted.	→Adjust.	Page 90
		Other (other than the above).	→Please contact your CANYCOM representative.	
	Machine vibrates	Track is loose.	→Adjust.	Page 90
		Track is derailed.	→Put it back and adjust its tension	
		Mount bolt on track roller, upper roller, sprocket, or idler is loose.	→Tighten.	
		Track roller bearing is damaged.	→Please contact your CANYCOM representative to replace..	
		Other (other than the above).	→Please contact your CANYCOM representative.	
	Machine does not travel straight.	Roller, upper roller, idler or sprocket is damaged.	→Repair or replace.	
		Other (other than the above).	→Please contact your CANYCOM representative.	
	Safety Devices	Light does not turn on.	Damaged wiring.	→Repair.
Blown fuse.			→Replace.	Page 102
Other (other than the above).			→Please contact your CANYCOM representative.	
Oil pressure warning stays on after the engine starts.		Low oil level.	→Fill.	Page 75
		Other (other than the above).	→Please contact your CANYCOM representative.	

Area	Malfunction	Possible Cause	Corrective Measure	Ref.
Safety Devices	Overheat warning stays on after the engine starts.	Engine is overheating.	→Refer to the Operator's Manual for the engine.	
		Other (other than the above).	→Please contact your CANYCOM representative.	
	Charge warning stays on after the engine starts.	Blown fuse.	→Replace.	Page 101
		Other (other than the above).	→Please contact your CANYCOM representative.	
	Horn does not work.	Blown fuse.	→Replace.	Page 101
		Other (other than the above).	→Please contact your CANYCOM representative.	

Hauling

Loading and Unloading

⚠ WARNING

- Park the transporter (truck) on a level ground and apply parking brake. Always use chocks to secure the wheels.
- Do not allow bystandars to come close to the machine or the transporter when loading or unloading the machine.
- Use only the loading ramps with sufficient strength (to withstand the combined weight of the machine and the operator), width (more than 1.2 times the width of the track), and length (more than 4 times the height of the bed of the transporter), and have anti-slip ramp surfaces.
- Secure the hooks of the loading ramps firmly and flush with the bed of the transporter.
- Move slowly foreward when loading onto, and move slowly backward when unloading off of the transporter. Pay special care when going over the joint between the bed and the ramps; the machine can tip.
- Do not turn on the loading ramps. The machine can fall.
- Tie down the machine securely. Make sure the machine does not move around on the bed of the transporter.

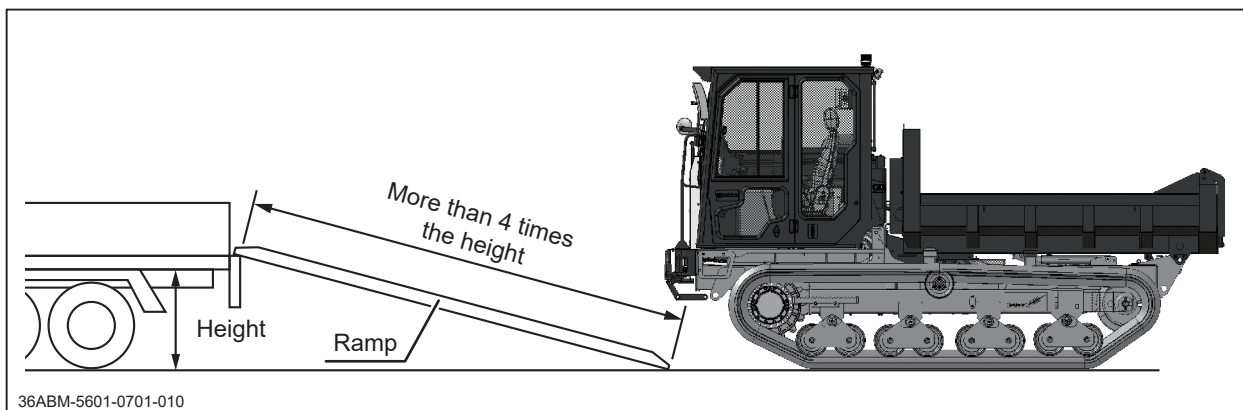

Loading to the Transporter

1. Park the transporter and apply parking brake. Secure the wheels with chocks.
2. Place the loading ramps. Secure the hooks of the ramps firmly and flush with the loading deck.
3. Set the H/L Speed Selector switch to [L] mode, turn the accelerator and speed knobs to [SLOW], and drive the machine slowly forward onto the loading deck.
4. Park the machine according to the instructions in **Parking** (page 44).
5. Tie the machine at lift hooks (hoist points) with rope or tie-down belts and secure it onto the loading deck of the transporter securely.

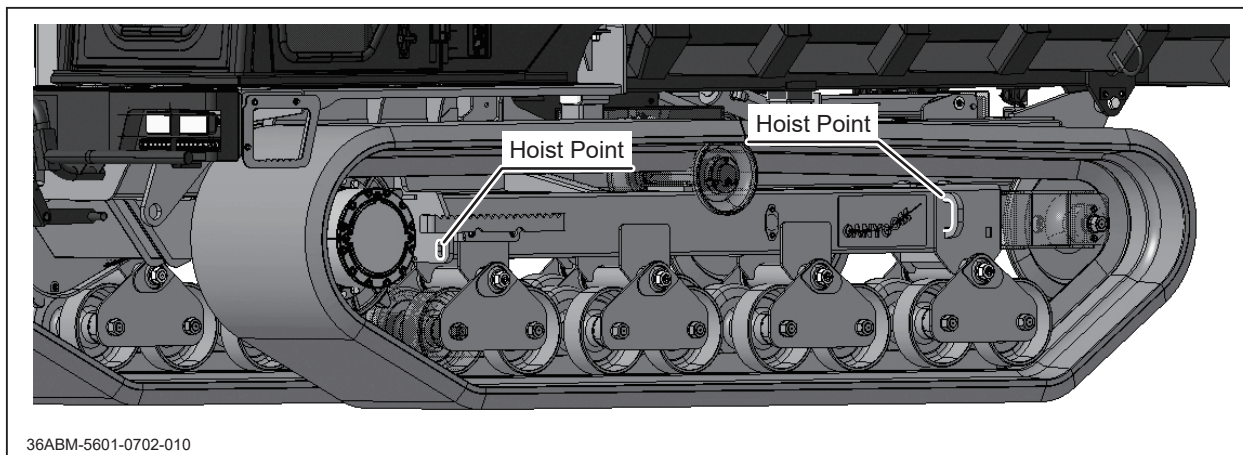

Unloading from the Transporter

1. Park the transporter and apply parking brake. Secure the wheels with chocks.
2. Undo rope or tie-downs that secure the machine.
3. Place the loading ramps. Secure the hooks of the ramps firmly and flush with the loading deck.
4. Set the H/L Speed Selector switch to [L] mode, turn the accelerator and speed knobs to [SLOW], and drive the machine slowly backward from the loading deck to the ground.

Hoisting and Towing

Hoisting

⚠ WARNING

- Hoisting requires qualifications. Check with your local authority for necessary qualifications and licenses for hoisting.
- Use hoisting wire rope, slings and hooks (shackles) of strength sufficient for the weight of the machine.
- Beware of the shift in the center of gravity and balance of the machine when hoisting.
- Always unload the machine before hoisting.

Hoisting one side of the machine (when changing tracks or track rollers)

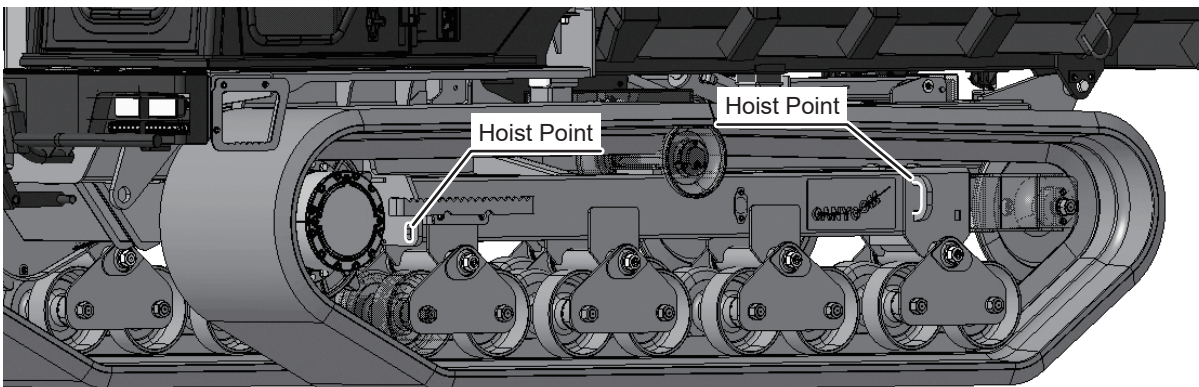

36ABM-5601-0702-010

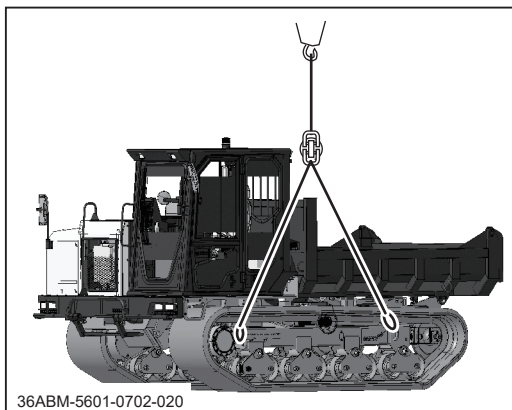

36ABM-5601-0702-020

Attach sling or wire rope to the hoist points on the side of the chassis that needs to be lifted and hoist.

Hoisting the whole machine

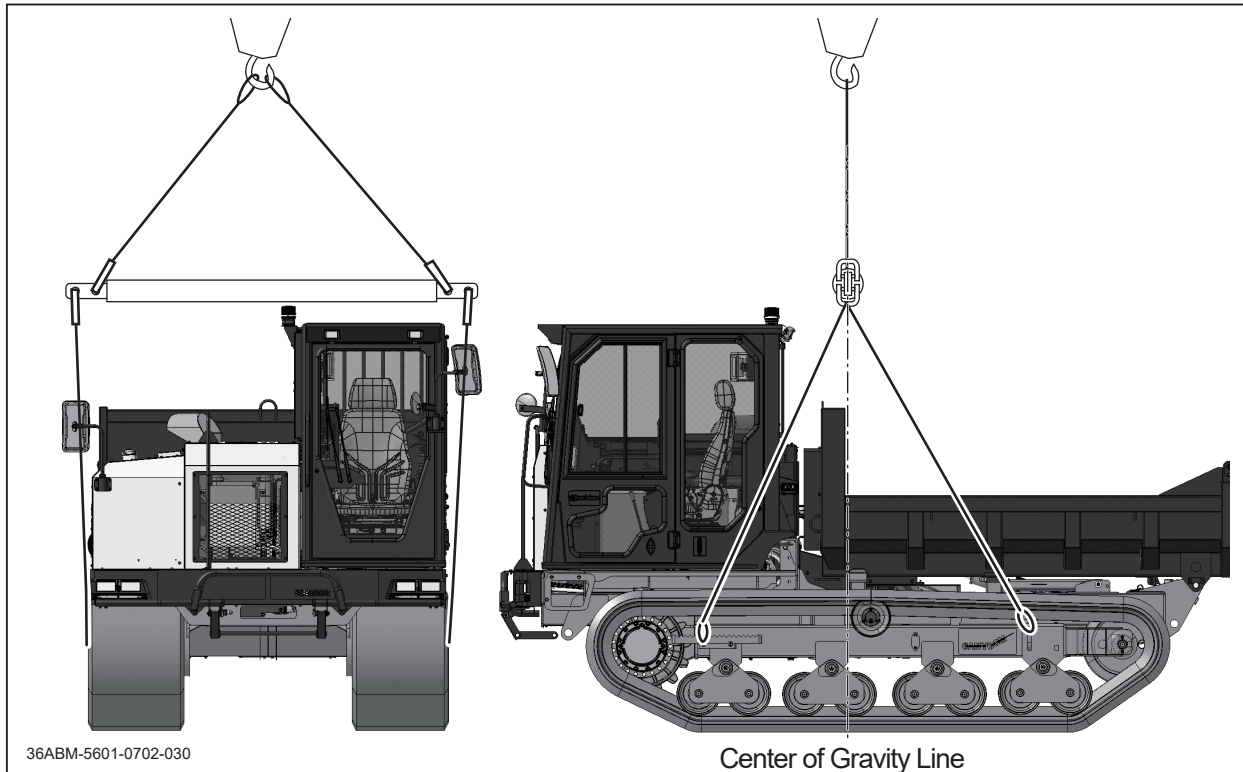

1. Raise the bucket and lock it with the safety prop (page 47).
2. Hitch the wire rope to the lifting hooks (4 places) attached to the frame and lift the machine. At this time, adjust the wire rope length so that the machine will be horizontal.
3. Slings work implements (wire, rope, chain, etc.) to be used should have sufficient strength.

Towing

NOTE

- The following are needed to perform this operation:

Socket Head Cap Screw: M10 X 1.5 standard pitch, L = 100mm, 2pieces.

M10 Plain Washer: O.D. 24mm or smaller, Thickness 1.5 -3.0mm, 2 pieces.

(ISO 7089, 7090, 7091, 7092 M10 standard or M10 fine is recommended.)

When the engine is running, you can tow this machine by turning the parking brake switch to [○(OFF)] position and moving the lock lever to [○(DRIVE)] position. When the engine can not be started, perform the following procedure.

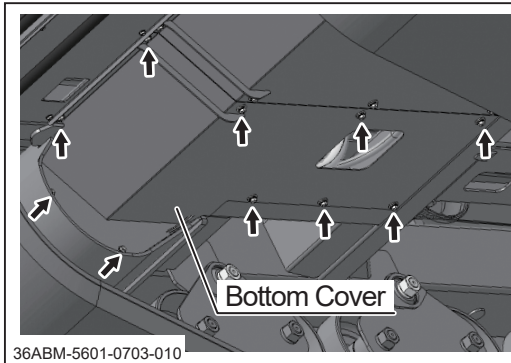

1. Undo ten (10) bolts to remove the bottom cover on the back side of the motor.

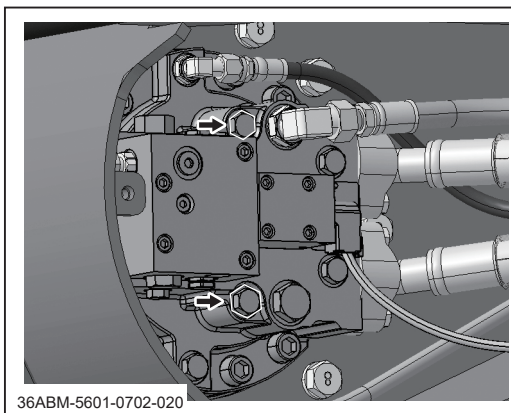

2. Remove the parking brake release port plugs (2 places, wrench size: 11/16 inch).

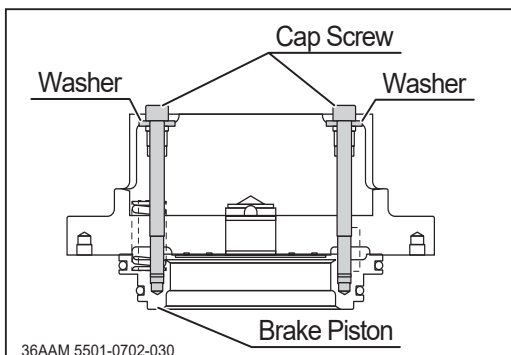

3. Thread the plain washer through the M10, L=100mm screw and insert into the brake release port.

NOTE

- Tighten the two screws evenly, or the motor can be damaged.

4. Tighten the two bolts evenly until they cannot be tightened further. This releases the brake, and the machine can be towed.

NOTE

- Oil may leak out of the brake release ports.

5. Once the machine is towed, undo the M10 screws and reinstall the parking brake release port plugs.

NOTE

- **Parking Brake Release Port Plugs**
tightening torque: 28Nm-48Nm.

NOISE LEVEL(ISO 6395:2008,ISO 6396:2008)

Model	Engine		LpA	LwA
Type	Type	Speed rpm	78 dB (A)	104 dB (A)
S500V	Kubota V3800	2500 rpm		

VIBRATION(ISO 5349:2001,ISO 2631:1997)

Model	Engine Speed	Vibration	
		Steering lever	Seat
S500V	2500 rpm	3.13 m/s ² (uncertainty K=0.45m/s ²)	0.95 m/s ² (uncertainty K=0.15m/s ²)

These values are test values and may differ from those in the actual operational condition.

CHIKUSUI CANYCOM, INC.

<https://www.canycom.jp/eng/>

CHIKUSUI CANYCOM, INC.
90-1 Fukumasu, Yoshii-machi,
Ukiha-shi, Fukuoka, Japan 839-1396

Authorized Dealer